

# **BONENG**



**A1变频驱动器**

**A1 Variable  
Frequency  
Drive**

Modified date 06/2024  
Selection Sample C05.0040

---

## **Boneng Transmission**

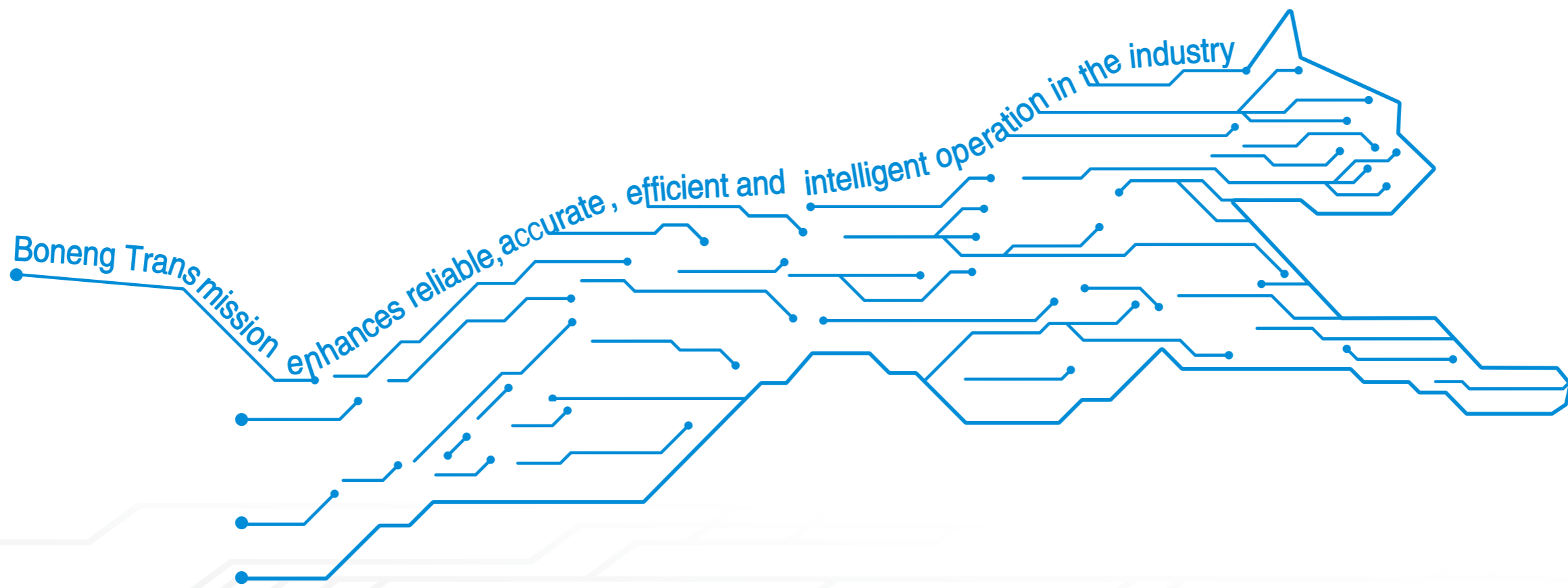

控制器/驱动器/马达/  
齿轮马达/齿轮箱

Controller/ Drive/ Motor/  
Gearmotor/ Gearbox

## A1变频驱动器

- ◆ 支持IM及PM电机的速度控制和扭矩控制
- ◆ 支持多种通讯协议：Modbus，CANopen，PROFINET
- ◆ 提供自由编程模块和参数互联，可根据现场工艺自由组合搭配
- ◆ 集成特色工艺功能，如PID控制器，随速随速，防摇摆，平稳回转等控制功能
- ◆ LCD支持中文，英文显示操作面板、PC上位机调试工具Boneng Drivesoft
- ◆ 书本型结构，满足电柜更多并排安装需求
- ◆ 内置A级滤波器（选配），并可外接滤波器，满足严苛的电磁等级要求
- ◆ 免螺丝压接式控制端子，无螺丝刀也能接线和维护
- ◆ 可拆卸式功率接线端子，功率电缆接线更便捷

## A1 Variable Frequency Drive

- ◆ Support speed control and torque control for IM and PM motors
- ◆ Support multiple communication protocols: Modbus, CANopen, PROFINET
- ◆ Provide free programming module and parameter interconnection, which can be combined and matched freely according to the on-site process
- ◆ Integrated characteristic functions, such as PID controller, adaptive speed with load, anti sway control, Smooth rotation, etc
- ◆ Status display via LCD Operator Panel in Chinese and English, Support commissioning software based PC—Boneng DriveSoft
- ◆ Slim booksize structure to meet side-by-side installation requirements in electrical cabinets
- ◆ Built-in A-class filter(optional), and external filter, meeting the strict electromagnetic level requirements
- ◆ Screw free crimping type of IO terminals can be connected and maintained without screw drive
- ◆ Detachable power terminal, power cable easy to installed conveniently



产品广泛应用于起重机、堆垛机、提升机、挤出机、研磨机、搅拌机、破碎机、拉丝机、卷板机、离心机等，物料输送、搬运，风机泵等各个领域。

博能传动公司总部和各大区域的技术专家以及各区域办事处的应用工程师、售后服务技师竭诚为您提供全面的技术咨询和完善的服务。

Products are widely used in Cranes, stackers, hoists, extruders, grinders, mixers, crushers, wire drawing machines, plate rolling machines, centrifuges, material transportation, handling, fan pumps and other fields. Boneng Transmission company headquarters and major regional technical experts and regional offices of the application engineers, after-sales service technicians dedicated to provide you with comprehensive technical advice and perfect service.



# 目录

# Catalogue

<b>1 Agile系列驱动器</b>	
1.1 概述	02
1.2 应用	09
1.3 PC-驱动器连接	10
1.4 技术参数	11
<b>2 PM25功率模块</b>	
2.1 概述	12
2.2 选型订货数据	13
2.3 电气连接	14
2.4 技术参数	16
2.5 特性曲线	20
2.6 外形尺寸	21
2.7 可选件	23
<b>3 CM25控制模块</b>	
3.1 概述	31
3.2 选型订货数据	32
3.3 设计	32
3.4 电气连接	34
3.5 技术参数	36
3.6 外形尺寸	38
<b>4 CM22控制模块</b>	
4.1 概述	39
4.2 选型订货数据	39
4.3 设计	40
4.4 电气连接	41
4.5 技术参数	42
4.6 外形尺寸	43
<b>5 CM23控制模块</b>	
5.1 概述	44
5.2 选型订货数据	44
5.3 设计	45
5.4 电气连接	46
5.5 技术参数	47
5.6 外形尺寸	48
<b>6 OP25操作面板</b>	
6.1 概述	49
6.2 选型订货数据	50
6.3 外形尺寸	50

<b>1 Agile series drivers</b>	
1.1 Summary	02
1.2 Applications	09
1.3 PC-drivers connection	10
1.4 Technical parameters	11
<b>2 PM25 Power Module</b>	
2.1 Summary	12
2.2 Selective ordering data	13
2.3 Electrical connection	14
2.4 Technical parameters	16
2.5 Characteristic curve	20
2.6 Dimensions	21
2.7 Options	23
<b>3 CM25 Control Module</b>	
3.1 Summary	31
3.2 Selective ordering data	32
3.3 Design	32
3.4 Electrical connection	34
3.5 Technical parameters	36
3.6 Dimensions	38
<b>4 CM22 Control Module</b>	
4.1 Summary	39
4.2 Selective ordering data	39
4.3 Design	40
4.4 Electrical connection	41
4.5 Technical parameters	42
4.6 Dimensions	43
<b>5 CM23 Control Module</b>	
5.1 Summary	44
5.2 Selective ordering data	44
5.3 Design	45
5.4 Electrical connection	46
5.5 Technical parameters	47
5.6 Dimensions	48
<b>6 PM25 Operation Panel</b>	
6.1 Summary	49
6.2 Selective ordering data	50
6.3 Dimensions	50



## 1 Agile系列驱动器

### 1.1 概述

Agile系列驱动器的设计目标是为交流电机提供高精度的速度/转矩控制及良好的伺服位置控制。

#### 整机构成

Agile系列驱动器是由多种不同功能模块组成,构成驱动器的主要模块为:

- ◆ 功率模块 (PM)
- ◆ 控制模块 (CM)
- ◆ 操作面板 (OP) (选配)
- ◆ 其它可选件

功率模块 (PM) 和控制模块 (CM) 是构成驱动器的两个必须模块



PM

CM

OP

DRIVER

#### 功率模块

功率模块范围为0.75kW-250kW,通过高性能微处理器控制,采用高可靠性IGBT,及先进的脉宽调制技术,使得电机调速极为灵活可靠,完善的保护功能为功率模块和电机提供可靠地保护。

#### 控制模块

支持多种方式对功率模块和所接入电机进行控制和监视,支持本地,远程IO及通讯等多种用户控制接口,以及多种控制模块,为客户的简单或复杂应用提供灵活的组合与搭配。

#### 操作面板

用于对驱动器的调试、运行监控以及输入参数的设置。LCD屏可以显示四行,每行最多8个汉字或者16个字母。

## 1 Agile series drivers

### 1.1 Summary

Agile series inverters are designed to provide high-precision speed /torque control and satisfy servo position control for AC motors.

#### Overall structure

Agile series drivers consist of different functional modules, the main modules are showing as follows:

- ◆ Power Module(PM)
- ◆ Control Module(CM)
- ◆ Operation Panel(OP)(Optional)
- ◆ Other Options

Power Module (PM) and Control Module (CM) are two necessary modules of the driver.

#### Power Module

Power module range is 0.75KW ~ 250kw, through high-performance microprocessor control, the use of high reliability IGBT, and advanced pulse width modulation technology, making motor speed regulation extremely flexible and reliable, perfect protection function for the power module and motor to provide reliable protection.

#### Control Module

Control module supports a variety of ways to control and monitor the power module and the connected motor, supports a variety of user control interfaces such as local, remote IO and communication, as well as a variety of control modules, and provides flexible combination and collocation for customers' simple or complex applications.

#### Operation Panel

Operation panel is used for debugging, supervising and setting input parameters of the driver. LCD screen can display four lines, each line up to 8 characters or 16 letters.



## 整机外形尺寸和安装尺寸图

PM25+CM25+OP25组合的整机外形尺寸和安装尺寸图B1~B6, 单位为mm

## Overall outline dimensions and installation dimensions

PM25+CM25+OP25 overall outline dimensions and installation dimensions B1~B6 (Unit:mm)

### ◆B1 (0.75 kW~3 kW)

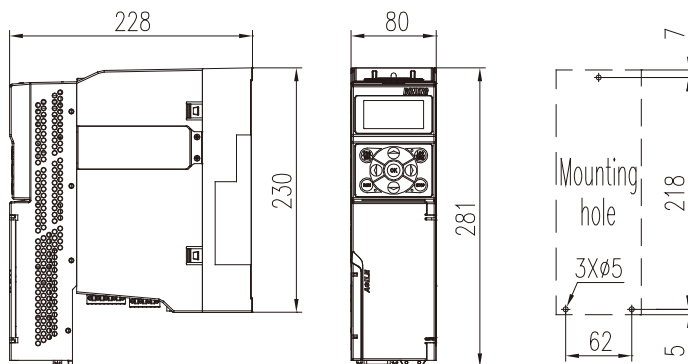

### ◆B2 (4 kW~7.5kW)

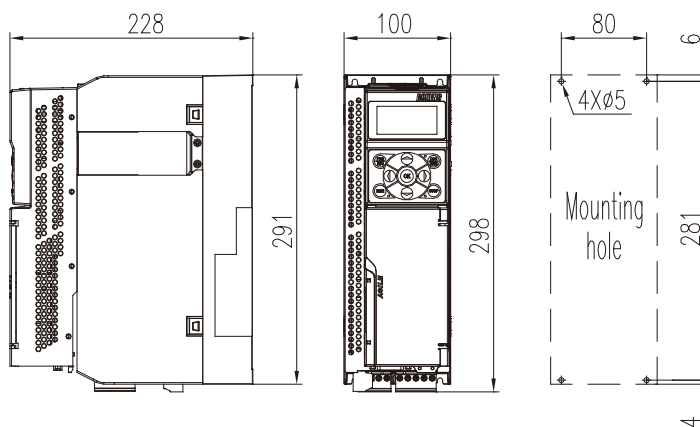

### ◆B3 (11 kW~15kW)

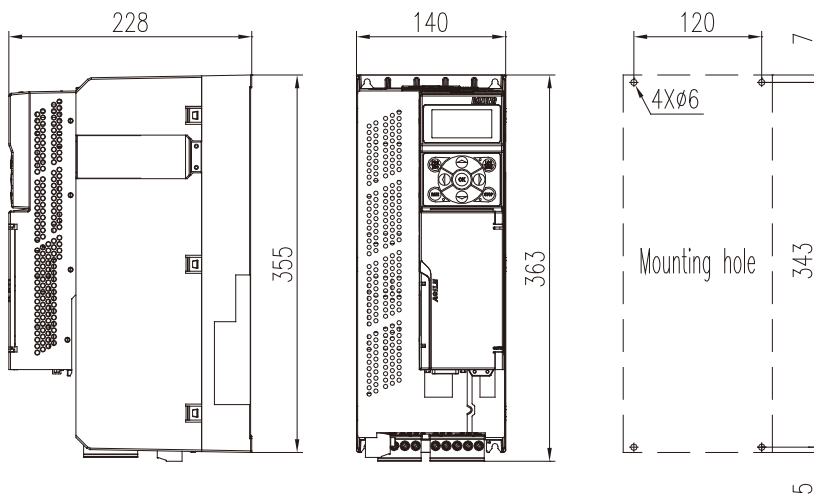

◆B4 (18.5 kW~37kW)

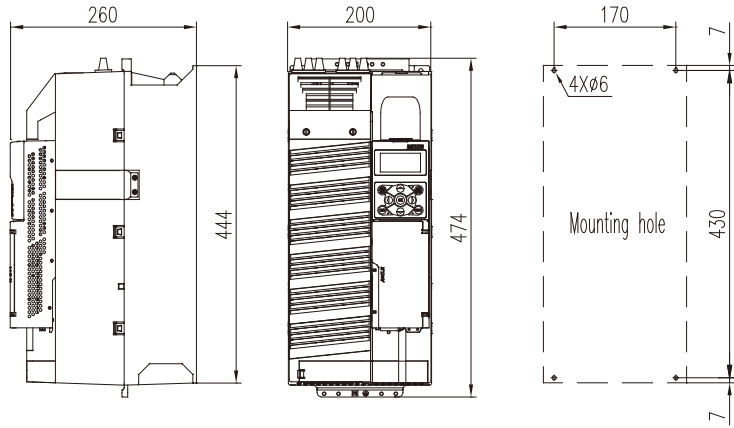

◆B6 (45 kW~132kW)

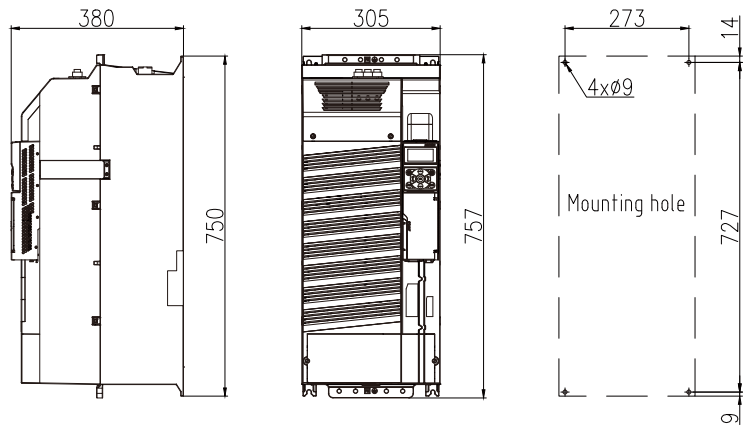

◆B7(160kW ~ 250kW)

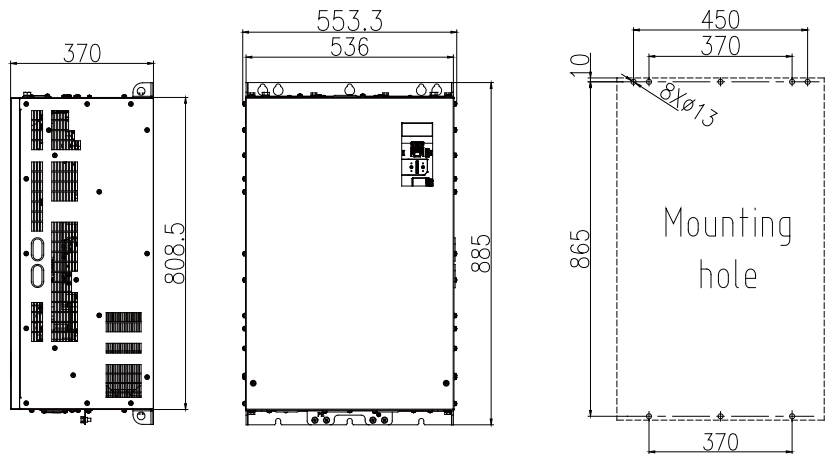

PM25+CM22+OP25组合的整机外形和尺寸图B1~B6, 单位为mm

PM25+CM22+OP25 overall outline dimensions and installation dimensions B1~B6 (Unit:mm)

◆B1 (0.75 kW~3 kW)

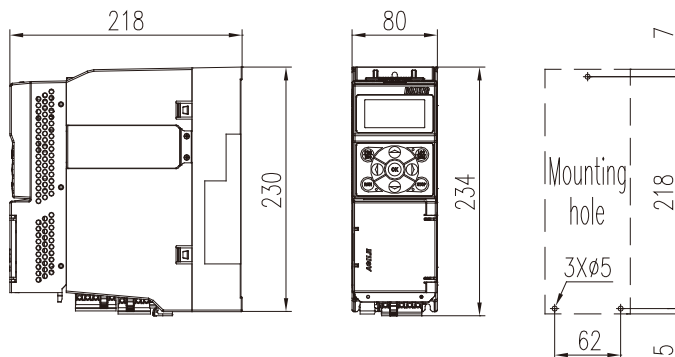

◆B2 (4 kW~7.5kW)

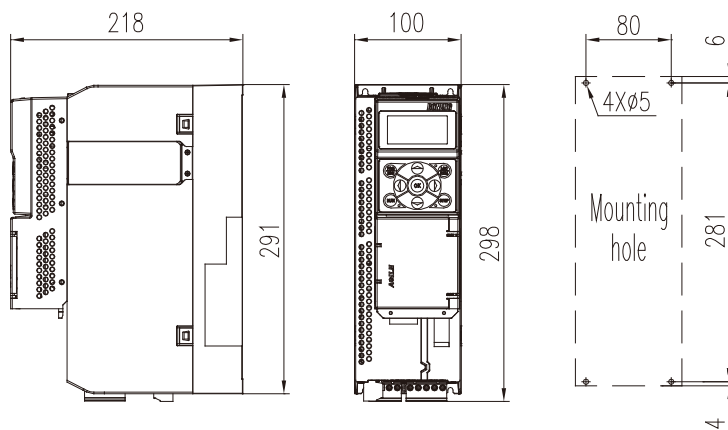

◆B3 (11 kW~15kW)

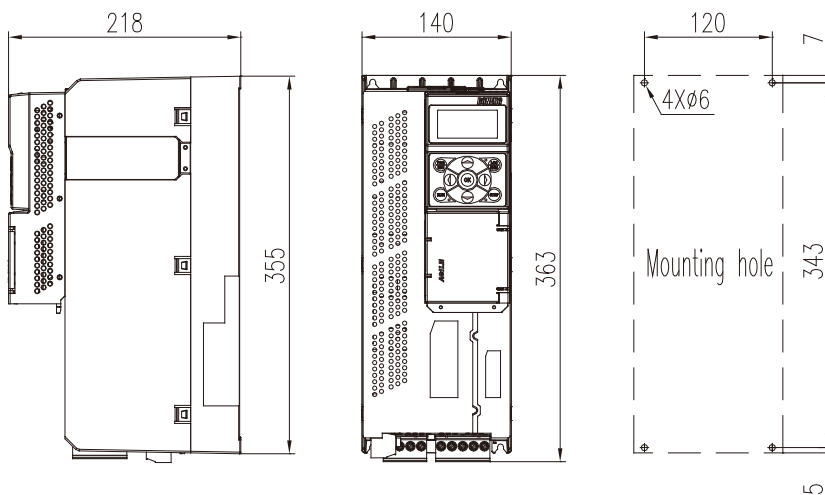

◆B4 (18.5 kW~37kW)

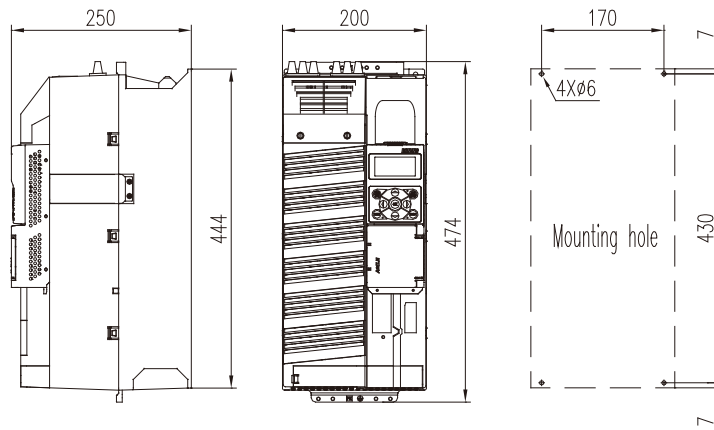

◆B6 (45 kW~132kW)

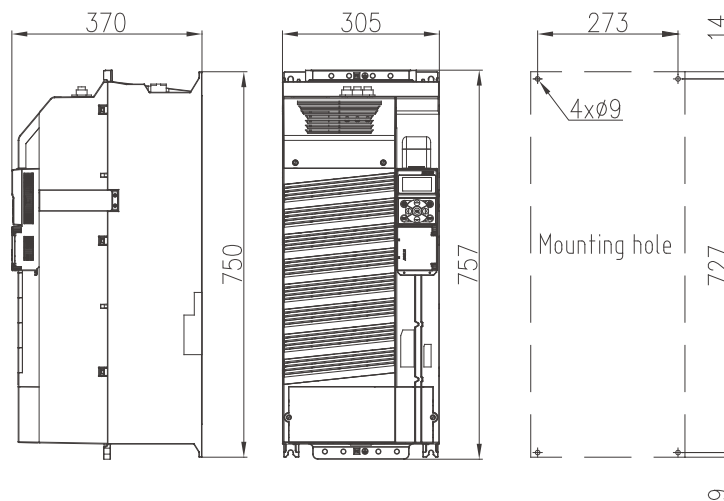

◆B7(160kW ~ 250kW)

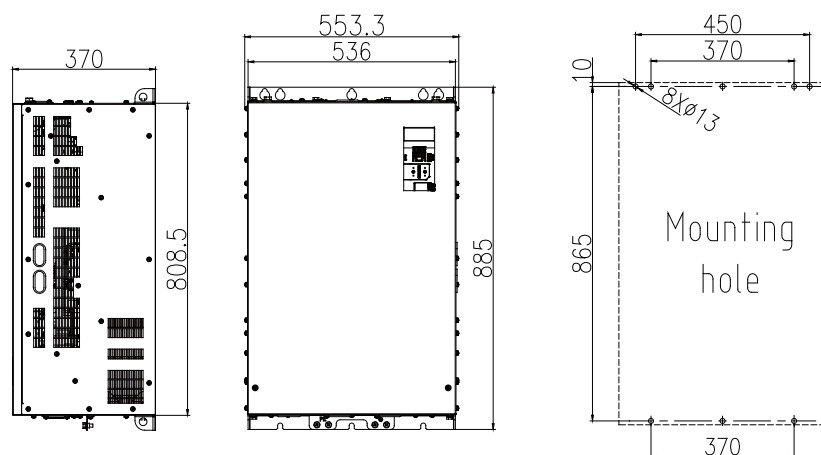

PM25+CM23+OP25组合的整机外形和尺寸图B1~B6, 单位为mm

PM25+CM23+OP25 overall outline dimensions and installation dimensions B1~B6 (Unit:mm)

◆B1 (0.75 kW~3 kW)

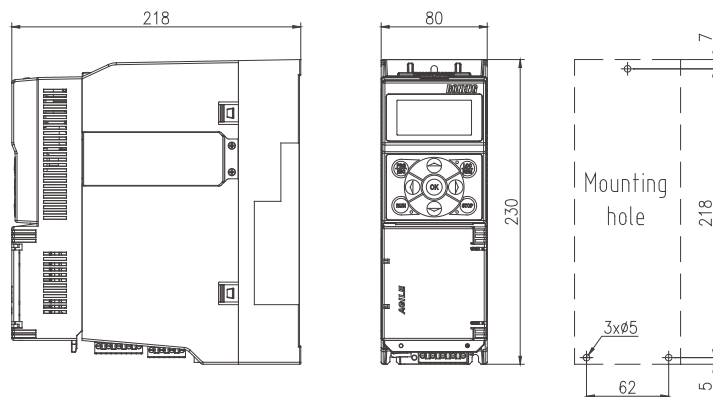

◆B2 (4 kW~7.5kW)

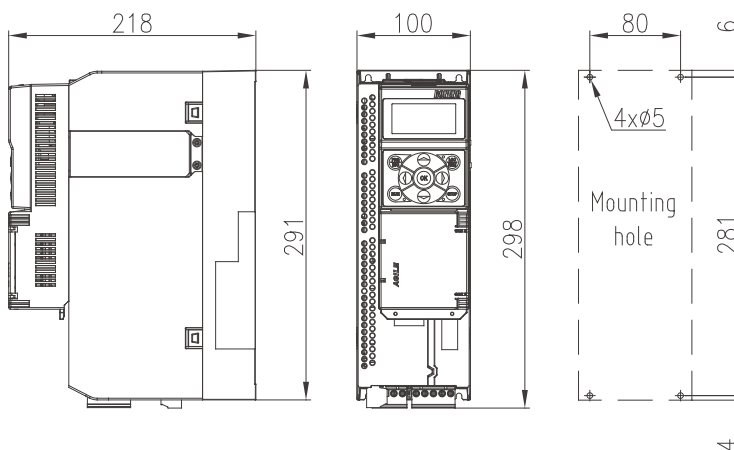

◆B3 (11 kW~15kW)

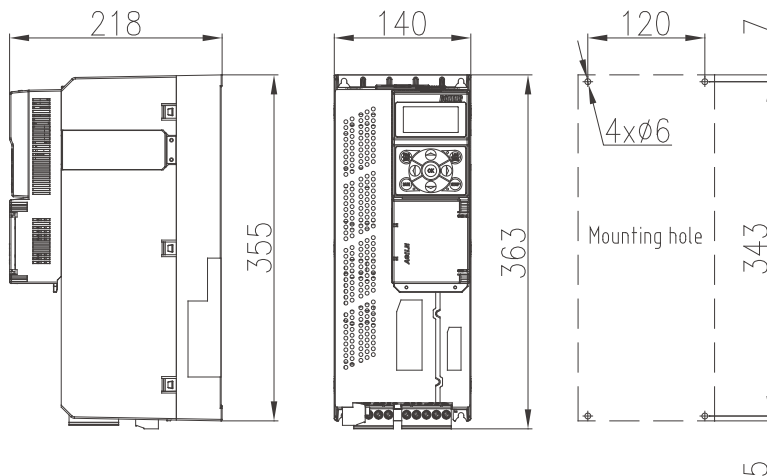

◆B4 (18.5 kW~37kW)

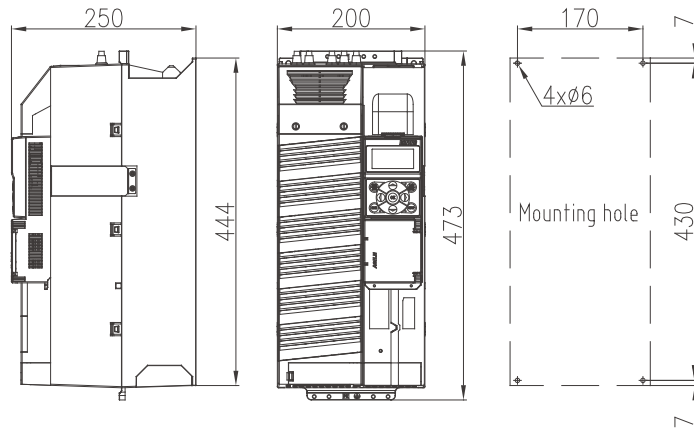

◆B6 (45 kW~132kW)

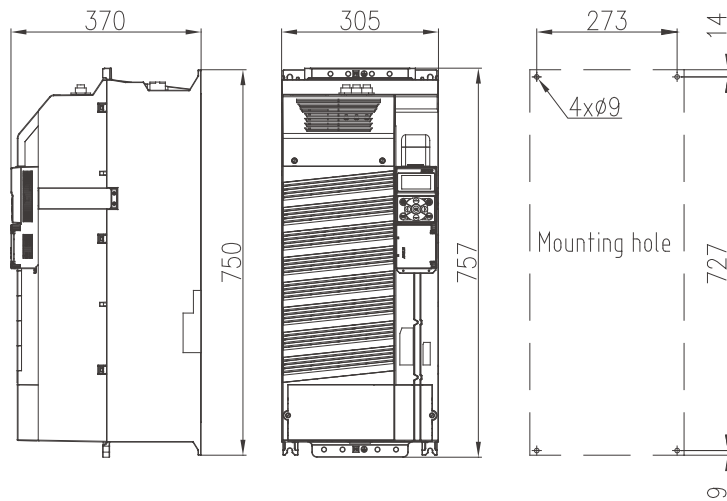

◆B7(160kW ~ 250kW)

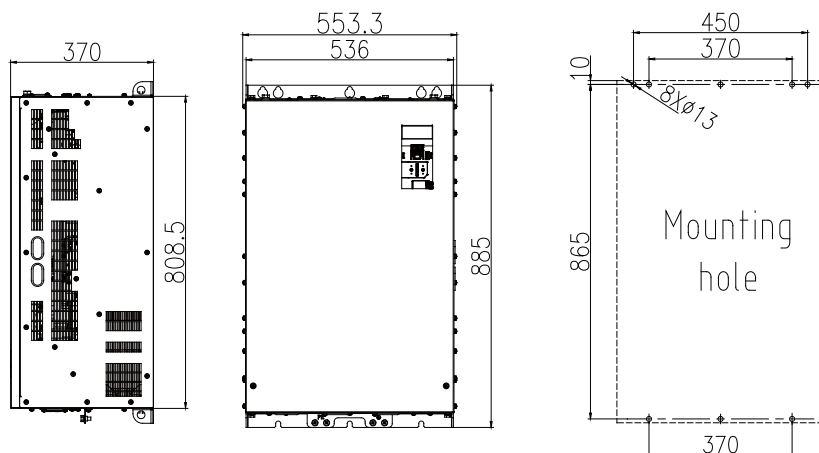

## 1.2 应用

## 1.2 Applications

驱动器组合 Drive combination	功率 Power	可驱动的电机类型 Drivable motor types	主要接口和功能 Main interfaces and functions		产品应用特色 Product application features
PM25+CM25	0.75kW-250kW	交流 AC 异步 asynchronous motor  交流 AC 同步 synchronous motor	DI	10ch	<ul style="list-style-type: none"> <li>● 标准型驱动产品</li> <li>● 丰富的接口及高性能驱动</li> <li>● 适合各类复杂的工艺应用</li> <li>● 控制模块内集成通讯及编码器功能, 无需另购各类扩展卡</li> <li>● 模块化书本型驱动器, 外形美观, 产品易更换, 便于维护</li> <li>● 控制端子为压接式免螺丝接线端子, 便于安装拆卸</li> <li>● 动力端子为插拔式易拆卸接线端子, 便于安装拆卸</li> </ul> <ul style="list-style-type: none"> <li>● Standard drive products;</li> <li>● Rich interface and high performance driver;</li> <li>● Suitable for all kinds of complex process applications;</li> <li>● Communication and encoder functions are integrated in the control module, so there is no need to purchase various expansion cards;</li> <li>● Modular Book driver, beautiful appearance, easy to replace and maintain;</li> <li>● The control terminal is crimped screw-free terminal, and easy to install and remove;</li> <li>● The power terminal is plug-in terminal, and easy to install and remove.</li> </ul>
			DO	2ch	
			AI	2ch	
			AO	2ch	
			继电器 Relay	2ch	
			编码器接口 Encoder interface	增量 Incremental	
			电机温度接口 Motor temperature interface	支持 OK	
			USB接口 USB interface	支持 OK	
			Modbus /CAN Modbus /CAN	支持 OK	
			操作面板接口 Operation panel interface	支持 OK	
线性/抛物线/可编程的V/F控制 Linear/parabolic/programmable V/F control	支持 OK				
无传感器的速度/扭矩矢量控制 Sensorless speed/torque vector control	支持 OK				
有传感器的速度/扭矩矢量控制 Speed/torque vector control with sensor	支持 OK				
PM25+CM22	0.75kW-250kW	交流 AC 异步 asynchronous motor  交流 AC 同步 synchronous motor	DI	5ch	<ul style="list-style-type: none"> <li>● 精简型驱动产品</li> <li>● 适合各类简单工艺应用</li> <li>● 更经济的驱动器配置方案</li> <li>● 控制模块内集成Modbus通讯及ABZ型编码器功能, 无需另购各种扩展卡</li> <li>● 模块化书本型驱动器, 外形美观, 产品易更换, 便于维护</li> <li>● 控制端子为压接式免螺丝接线端子, 便于安装拆卸</li> <li>● 动力端子为插拔式易拆卸接线端子, 便于安装拆卸</li> </ul> <ul style="list-style-type: none"> <li>● Lean drive products;</li> <li>● Suitable for all kinds of simple process applications;</li> <li>● More economical drive configuration scheme;</li> <li>● Modbus communication and ABZ encoder functions are integrated in the control module, so there is no need to purchase various expansion cards;</li> <li>● Modular Book driver, beautiful appearance, easy to replace and maintain;</li> <li>● The control terminal is crimped screw-free terminal, and easy to install and remove;</li> <li>● The power terminal is plug-in terminal, and easy to install and remove.</li> </ul>
			AI	2ch	
			AO	1ch	
			继电器 Relay	1ch	
			编码器接口 Encoder interface	增量 Incremental	
			Modbus Modbus	支持 OK	
			操作面板接口 Operation panel interface	支持 OK	
			线性/抛物线/可编程的V/F控制 Linear/parabolic/programmable V/F control	支持 OK	
无传感器的速度/扭矩矢量控制 Sensorless speed/torque vector control	支持 OK				
有传感器的速度/扭矩矢量控制 Speed/torque vector control with sensor	支持 OK				
PM25+CM23	0.75kW-250kW	交流 AC 异步 asynchronous motor  交流 AC 同步 synchronous motor	DI	6ch	<ul style="list-style-type: none"> <li>● 行业专用型驱动产品, 优化的行业应用模式</li> <li>● 非常适合起重行业应用, 集成220V抱闸继电器及完善的抱闸逻辑控制功能</li> <li>● 控制模块内集成Modbus通讯及ABZ型编码器功能, 无需另购各种扩展卡</li> <li>● 模块化书本型驱动器, 外形美观, 产品易更换, 便于维护</li> <li>● 控制端子为压接式免螺丝接线端子, 便于安装拆卸</li> <li>● 动力端子为插拔式易拆卸接线端子, 便于安装拆卸</li> </ul> <ul style="list-style-type: none"> <li>● Industry specific drive products and optimized industry application mode;</li> <li>● It is very suitable for the application of lifting industry, integrating 220 V holding brake relay and perfect holding brake logic control function;</li> <li>● Modbus communication and ABZ encoder functions are integrated in the control module, so there is no need to purchase various expansion cards;</li> <li>● Modular Book driver, beautiful appearance, easy to replace and maintain;</li> <li>● The control terminal is crimped screw-free terminal, and easy to install and remove;</li> <li>● The power terminal is plug-in terminal, and easy to install and remove.</li> </ul>
			继电器 Relay	2ch	
			编码器接口 Encoder interface	增量 Incremental	
			Modbus PROFINET Modbus PROFINET	支持 OK	
			操作面板接口 Operation panel interface	支持 OK	
			无传感器的速度/扭矩矢量控制 Sensorless speed/torque vector control	支持 OK	
有传感器的速度/扭矩矢量控制 Speed/torque vector control with sensor	支持 OK				



## 1.3 PC-驱动器连接

如果安装了合适的驱动软件,PC机可以直接通过控制模块上的操作面板接口对驱动器进行控制和调试,此软件可以在博能的官方网站下载。由于共用控制模块的操作面板接口,PC软件和OP25操作面板不能同时使用。后期将开发PC软件使用USB接口,以便支持PC软件和OP25共用。驱动器调试软件,可以为调试、优化和诊断提供菜单帮助向导。

## 1.3 PC-Drivers connection

If the appropriate driver software is installed, the PC can control and debug the driver directly through the operation panel of the control module. This software can be downloaded from the official website of BONENG. PC software and OP25 operation panel can not be used at the same time because they share the operation panel interface of control module. Later, PC software will be developed to use USB interface to support the sharing of PC software and OP25. Driver debugging software can provide menu help wizard for debugging, optimization and diagnosis.

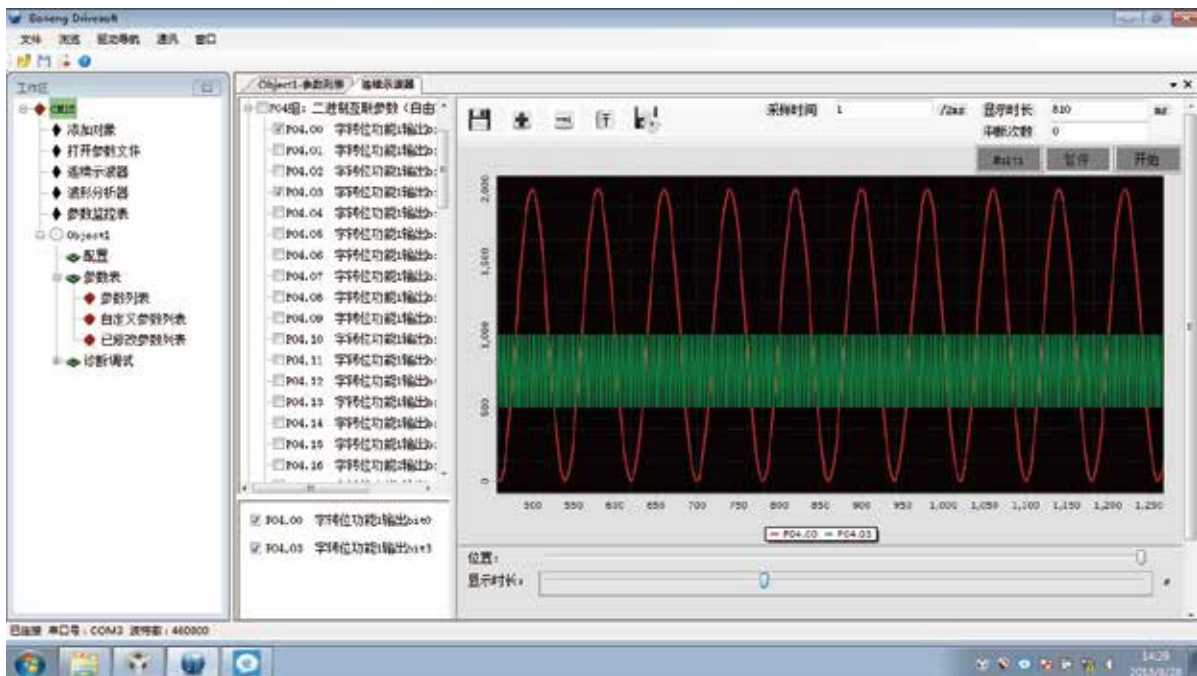
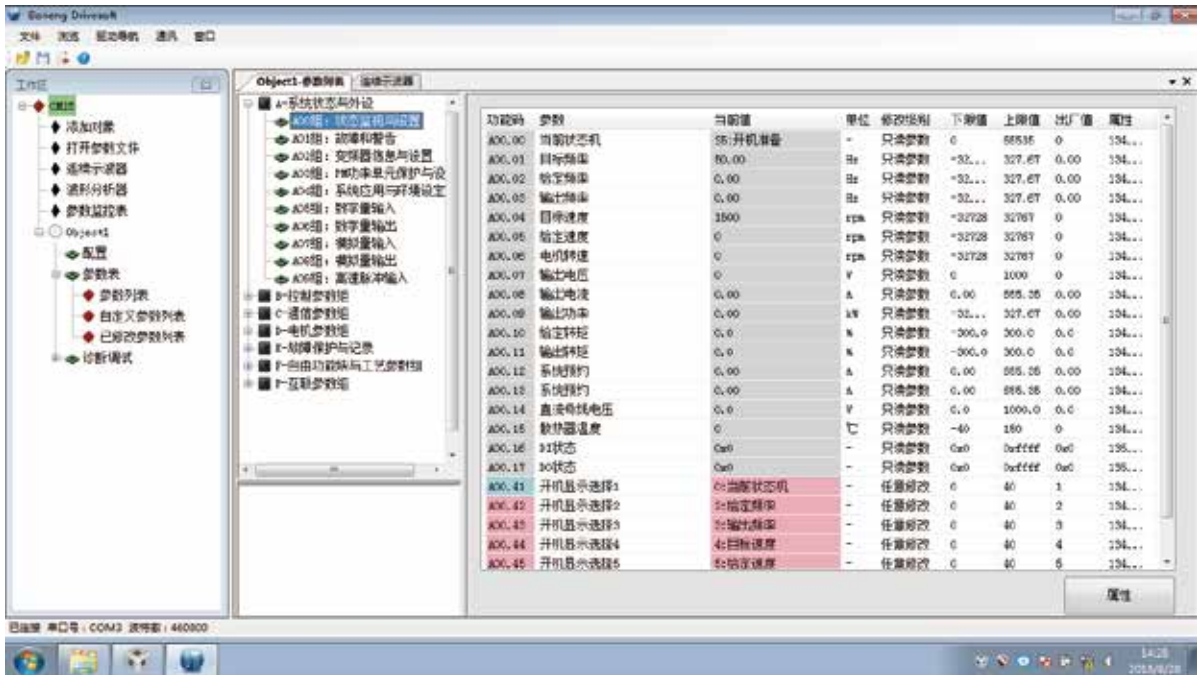



## 1.4 技术参数

如果不做特殊说明, 那么Agile系列驱动器将符合以下的技术参数

## 1.4 Technical parameters

If no otherwise instructions, then Agile series drivers will meet the following technical parameters.

机械参数		Mechanical parameters	
振动		Vibration	
•运输	•Transportation	等级2M3符合IEC 60068-2-6	Class 2M3 comply with IEC 60068-2-6
•运行	•Operation	等级3M4符合IEC 60068-2-6	Class 3M4 comply with IEC 60068-2-6
		10Hz~58Hz: 恒定振幅0.075 mm 58Hz~200Hz: 恒加速度=9.81 m/s <sup>2</sup> (1g)	10Hz ~ 58Hz: constant amplitude 0.075 mm 58Hz ~ 200Hz: constant acceleration = 9.81 M / S <sup>2</sup> (1g)
冲击		Impact	
•运输	•Transportation	等级2M2符合IEC 60068-2-27	Class 2M2 comply with IEC 60068-2-27
•运行	•Operation	等级3M4符合IEC 60068-2-27	Class 3M4 comply with IEC 60068-2-27
		49 m/s <sup>2</sup> (5g) /30 ms	49 m/s <sup>2</sup> (5g) /30 ms
环境条件		Environment condition	
防护等级	Protection level	等级 I (带有保护接地的系统) 和等级 III (PELV), 对应于 IEC 61800-5-1	Class I (system with earthing protection) and class III (PELV) correspond to IEC 61800-5-1;
冲击防护	Impact protection	当正确使用时符合 IEC 61800-5-1	Comply with IEC 61800-5-1 when used correctly
运行过程中功率模块功率部件允许的环境和冷却介质温度		Allowable environment and cooling medium temperature of power components of power module during operation	
•重载 (HD)	•Heavy duty (HD)	-20°C~+50°C不降容, >50°C~60°C, 参见降容曲线	No capacity reduction at -10°C~+50°C, see capacity reduction curve at >50°C~60°C
•轻载 (LD)	•Light duty (LD)	-20°C~+40°C不降容, >40°C~60°C, 参见降容曲线	No capacity reduction at -10°C~+40°C, see capacity reduction curve at >40°C~60°C
运行过程中控制模块和附加系统部件允许的环境和冷却介质温度	Allowable environment and cooling medium temperature of control module and additional system components during operation	-20°C~+50°C	-20°C~+50°C
气候环境条件		Climatic and environmental conditions	
•保存	•Preservation		
•运输	•Transportation	符合IEC60721-3-2的2K4, 温度-40°C~+70°C, 最大空气湿度40°C下95%	2K4 according to IEC60721-3-2, temperature 40°C~+70°C, maximum air humidity is 95% at 40°C
•运行	•Operation	符合IEC60721-3-3的3K5, 不允许有结露、水溅和结冰(IEC 60204, Part 1)	3K5 conforming to IEC60721-3-3, no condensation, water splashing and icing (IEC 60204, Part 1)
环境标准/有害化学物质		Environmental standards / hazardous chemicals	
•保存	•Preservation	符合IEC60721-3-1的1C2标准	Comply with 1C2 standard of IEC60721-3-1
•运输	•Transportation	符合IEC60721-3-2的2C2标准	Comply with 2C2 standard of IEC60721-3-2
•运行	•Operation	符合IEC60721-3-3的3C2标准	Comply with 3C2 standard of IEC60721-3-2
标准		Standard	
符合的标准	Standards met	UL, CE	UL, CE
CE认证	CE certification	符合低压规范 73/23/EEC和机械规范98/37/EC	Comply with low voltage specification 73/23/EEC and mechanical specification 98/37/EC
EMC规范		EMC standard	
•未内置A级进线滤波器	•No built in A-class incoming line filter	无电源滤波功能	No power filter function
•仅内置A级进线滤波器	•Only built in A-class incoming line filter	符合IEC 61800-3传导干扰C2类	Comply with class 2 conducted interference IEC61800-3
•未内置A级进线滤波器, 客户自配B级进线滤波器	•No built in A-level incoming line filter, and the customer has its own B-level incoming line filter	符合IEC 61800-3传导干扰C1类	Comply with class 2 conducted interference IEC61800-3
•内置A级进线滤波器, 客户自配B级进线滤波器	•Built in A-level incoming line filter, and the customer has its own B-level incoming line filter	符合IEC 61800-3传导干扰C1类	Comply with class 2 conducted interference IEC61800-3

## 2 PM25功率模块

## 2 PM25 Power Module

### 2.1 概述

### 2.1 Summary



PM25功率模块外形尺寸B1~B7

PM25 Power Module sizes B1 to B7

PM25功率模块是为有安全保护要求的应用场合而设计的, 与带有安全保护功能的控制模块组合使用, 组成带有集成安全保护功能的驱动器。

PM25功率模块对直流母线电压有足够的控制范围, 可以很容易地保证应用电压的变化。例如: 动态缓冲功能 (通过将负载的动能以再生方式回馈到直流母线来维持直流母线的电压) 或者在电源故障后, 通过利用负载生成的动能来控制并进行安全减速。此外, 几个PM25功率模块可以通过这种方式进行电气耦合 (共直流母线)。

PM25功率模块B1~B6规格可分为内置A级滤波器和未内置A级滤波器两种型号。功率模块PM25可在IT电网、TN电网、TT电网上运行, 但内置了A级进线滤波器或者用户自配了B级进线滤波器的功率模块均不允许在IT电网、带有接地相线的TN电网、不带接地星点的TT电网上运行。

PM25功率模块B1~B6规格都集成了内置的制动单元 (制动斩波器), 外部制动电阻可以通过DC+和R直接接在驱动器上。

PM25 power modules are designed for applications with safety protection requirements. It is combined with the control module with safety protection function to form a driver with integrated safety protection function.

PM25 power modules have enough control range for DC bus voltage, which can easily ensure the change of applied voltage. For example: dynamic buffering function (maintaining the voltage of DC bus by regenerating the kinetic energy of load to DC bus) or controlling and slowing down safely by using the kinetic energy generated by load after power failure. In addition, several PM25 power modules can be electrically coupled in this way (common DC bus).

The specifications of PM25 power modules B1 to B6 can be divided into two types: built-in A-level filter and no built-in A-level filter. The power modules PM25 can operate in IT power grid, TN power grid and TT power grid, but the power modules with A-level incoming line filter or user's own B-level incoming line filter are not allowed to operate in IT power grid, TN power grid with grounding phase line and TT power grid without grounding star point.

PM25 power modules B1 to B6 are integrated with built-in brake unit (brake chopper), and the external brake resistance can be directly connected to the actuator through DC + and R.

## 2.2 选型订货数据

## 2.2 Selection ordering data

型号表示方法

Model indication method

博能敏捷系列驱动器

BONENG Agile Series Drivers

版本号

Version number

功率模块

Power module

电压等级

Voltage level

B=400V AC

B=400V AC

输入相数

Number of input phases

=三相输入3φ

3=Three-phase input 3φ

功率代号

Power code

内置滤波器代号

Built-in filter code

N=不带内置滤波器代号

N=Without built-in filter code

F=带内置滤波器代号

F=With built-in filter code

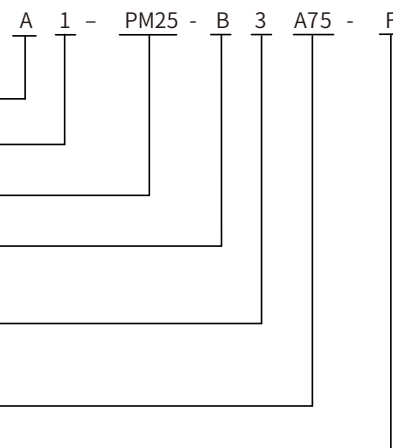

订货数据

Ordering data

LD模式				HD模式				外形尺寸		型号	
LD mode		HD mode		Dimen-		Model					
额定功率 kW	Rated power (kW)	额定电流 A	Rated current (A)	额定功率 kW	Rated power (kW)	额定电流 A	Rated current (A)	尺寸	Dimensions	(不带内置滤波器)	Without built-in filters
0.75	2.2	0.75	2.2	B1	A1-PM25-B3A75-N						
1.5	4.1	1.1	3.1		A1-PM25-B3B15-N						
2.2	5.9	1.5	4.1		A1-PM25-B3B22-N						
3	7.7	2.2	5.9		A1-PM25-B3B30-N						
4	10.2	3	7.7	B2	A1-PM25-B3B40-N						
5.5	13.2	4	10.2		A1-PM25-B3B55-N						
7.5	18	5.5	13.2		A1-PM25-B3B75-N						
11	26	7.5	18	B3	A1-PM25-B3C11-N						
15	32	11	26		A1-PM25-B3C15-N						
18.5	38	15	32	B4	A1-PM25-B3C18-N						
22	45	18.5	38		A1-PM25-B3C22-N						
30	60	22	45		A1-PM25-B3C30-N						
37	75	30	60		A1-PM25-B3C37-N						
45	90	37	75	B6	A1-PM25-B3C45-N						
55	110	45	90		A1-PM25-B3C55-N						
75	145	55	110		A1-PM25-B3C75-N						
90	178	75	145		A1-PM25-B3C90-N						
110	205	90	178		A1-PM25-B3D11-N						
132	250	110	205	B7	A1-PM25-B3D13-N						
160	302	132	250		A1-PM25-B3D16-N						
200	370	160	302		A1-PM25-B3D20-N						
250	477	200	370		A1-PM25-B3D25-N						

1. 若需订购带内置滤波器的功率模块, 请咨询厂家。

1. For power module with filter, consulting manufacturer

## 2.3 电气连接

PM25功率模块具有以下标准的接口：

◆PM-Interface接口用于PM25功率模块和控制模块之间的连接。

PM25功率模块同时通过一个集成的电源插口为控制模块提供电源

◆连接外部制动电阻的接口DC+和R

◆电机的连接通过压紧螺丝或者螺钉

◆2×PE(保护地)连接

## 2.3 Electrical connection

PM25 power module has the following standard interfaces:

◆ PM-Interface is used for the connection between PM25 power module and Control module.

PM25 power module provides power for the Control module through an integrated power plug-in.

◆ Connect the interface DC + and R of external braking resistor.

◆ The motor is connected by pressing screws or screws.

◆ 2×PE (earthing protection) connection.

电气连接 (续)

Electrical connection (continued)

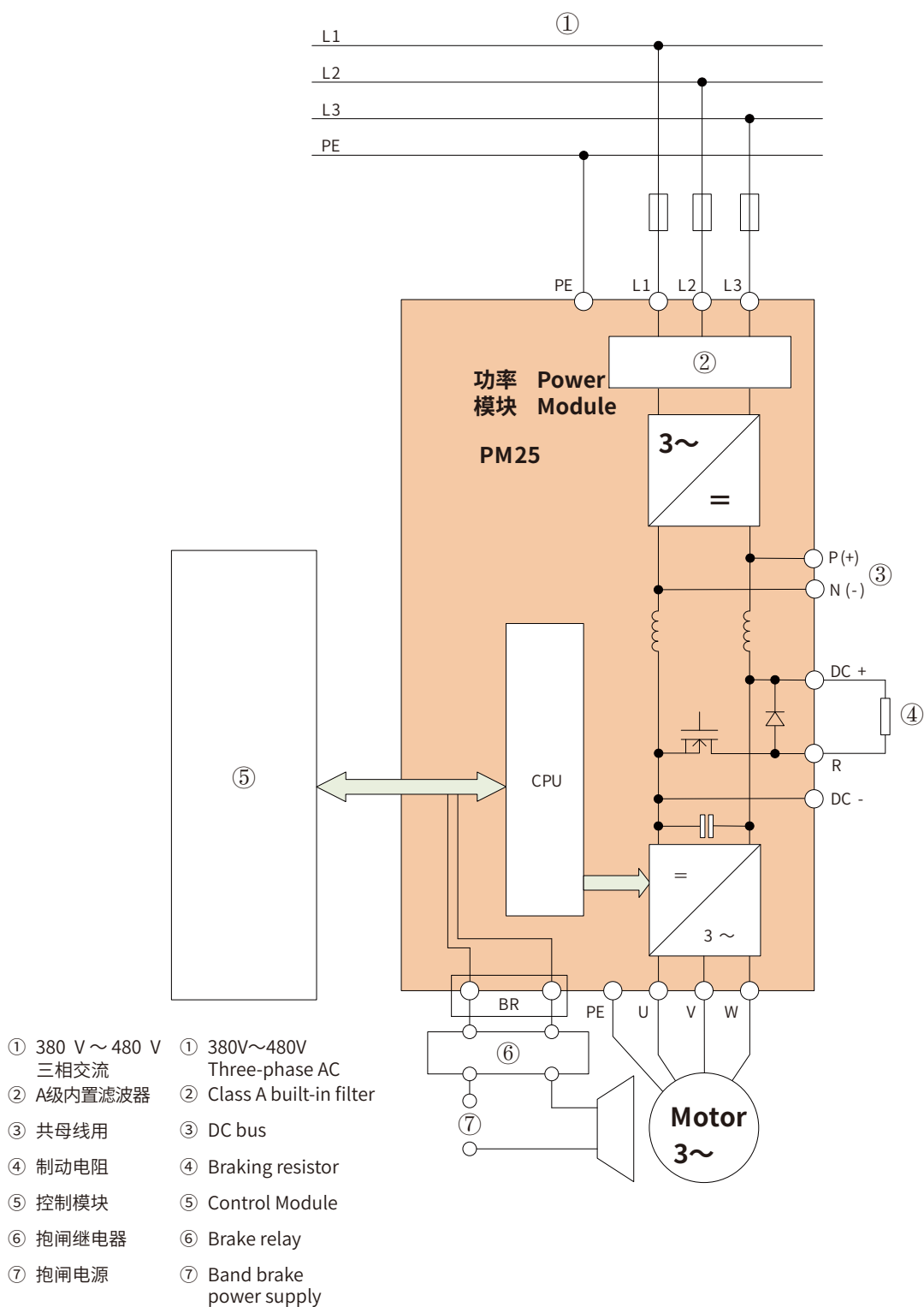

PM25功率模块电气接线图  
(内置/无内置滤波器)

PM25 power module electrical wiring diagram  
(with or without built-in filter)

## 2.4 技术参数

## 2.4 Technical parameters

		PM25功率模块基本技术参数		Technical parameters of PM25 power module	
输入电压	Input voltage	380~480V 3AC ±10%	380~480V 3AC ±10%		
电源要求	Power requirements	电源短路 电压Uk	Short circuit voltage Uk	无特殊要求	No special needs
输入频率	Input Frequency	47~63Hz	47~63Hz		
输出频率	Output Frequency	•V/F控制	V/F Control	0~300Hz	0~300Hz
		•矢量控制	Vector Control	0~200Hz	0~200Hz
载波频率	Carrier Frequency	90kW以下 4kHz,110kW 以上2kHz	4kHz(≤90KW), 2kHz(≥90KW)	对于其他更高的载波 频率参见降容数据表	For other higher carrier frequencies, see the reduced capacity data table
功率因数	Power Factor	0.95	0.95		
控制器效率	Controller Efficiency	95~97%	95~97%		
过载能力	Carrier Frequency	•重载 (HD)	Heavy duty(HD)	1.5倍额定输出电流 1min, 2倍额定输出电 流3sec, 周期10min	1.5 times the rated output current for 1 minute, 2 times the rated output current for 3 seconds, and the cycle is 10 minutes
		•轻载 (LD)	Light duty(LD)	1.2倍额定输出电流 1min, 1.5倍额定输出 电流3sec, 周期10min	1.2 times the rated output current for 1 minute, 1.5 times the rated output current for 3 seconds, and a cycle of 10 minutes
电磁兼容	Electromagnetic Compatibility	可选符合EN 55011标准的 A级和B级 滤波器	Optional Class A and Class B filters that in accordance with the standard EN 55011		
可选的制 动方式	Possible braking methods	•DC制动	DC braking		
		•复合制动	Compound braking		
		•动态制动, 内置制动斩 波器	Dynamic braking with integrated braking chopper		
防护等级	Protection level	IP20	IP20		
工作温度	Operating temperature	•重载(HD)	Heavy duty(HD)	-20°C~+50°C不降容, >50 °C~60°C, 参见降容曲线	-10°C to +50°C without derating, >50...60 °C see derating characteristics
		•轻载(LD)	Light duty(LD)	-20°C~+40°C不降容, >40 °C~60°C, 参见降容曲线	-10°C to +40°C without derating, >40...60 °C see derating characteristics
存储温度	Storage temperature	-40°C~+70°C	-40°C~+70°C		
相对湿度	Relative humidity	<95% RH, 无结露	<95%RH,condensation not permissible		
冷却方式	Cooling way	内部风冷	Internal air cooling	功率部分采用内置风扇强 制风冷(部分机型)	Power modules with increased air cooling by built-in fans(Partial type)
安装海拔 高度	Installation altitude	海拔1000m 内不降容, > 1000m参见 降容曲线	No capacity reduction within 1000 meters above sea level, see capacity reduction curve at >1000 meters above sea level		
标准SCCR	Standard SCCR	小于100kA	< 100 kA		
保护功能	Protection functions	•欠电压	Undervoltage		
		•过电压	Overvoltage		
		•过载	Overload		
		•接地故障	Earthing fault		
		•短路	Short-circuit		
		•电机抱闸 保护	Motor blocking protection		
		•电机过温	Motor overtemperature		
		•变频器过 温	Inverter overtemperature		
•参数互锁	Parameter interlocking				
符合的标 准	Standards met	UL、CE	UL、CE		
CE认证	CE Certification	符合低压规范 73/23/EEC和 机械规范 98/37/EC	Complies with Low Voltage Specification 72/23/EEC and Mechanical Specification 98/37/EC		

## 技术参数 (续)

## Technical Parameters (continued)

PM25功率模块进线电压380...480V 3AC			PM25 power module incoming voltage 380...480V 3AC						
技术参数		Technical data	A1-PM25-B3A75	A1-PM25-B3B15	A1-PM25-B3B22	A1-PM25-B3B30	A1-PM25-B3B40	A1-PM25-B3B55	A1-PM25-B3B75
额定输出功率	Rated output power	基于(LD) kW	-	1.5	2.2	3	4	5.5	7.5
		基于(HD) kW	0.75	1.1	1.5	2.2	3	4	5.5
额定输入电流	Rated input current	带进线电抗器 A	2.3	4.3	6.1	8	10.4	15.3	18.7
		不带进线电抗器 A	2.6	4.9	7.6	10.2	13.4	17.2	21.9
额定输出电流	Rated output current	基于(LD) A	-	4.1	5.9	7.7	10.2	13.2	18
		基于(HD) A	2.2	3.1	4.1	5.9	7.7	10.2	13.2
额定载波频率	Rated carrier frequency	kHz	4	4	4	4	4	4	4
效率 η	Efficiency η		>0.95	>0.95	>0.95	>0.95	>0.95	>0.95	>0.95
功率损失	Power loss	kW	0.1	0.11	0.14	0.16	0.18	0.24	0.3
冷却风量要求	Cooling air volume requirement	m <sup>3</sup> /s	0.005	0.005	0.005	0.024	0.024	0.055	0.055
噪声水平	Noise level	dB(A)	<40	<40	<40	<40	<50	<50	<50
24V DC输出电源(控制单元用)	24V DC output power supply (to control unit)		1	1	1	1	1	1	1
制动电阻连接电缆的最大长度	Length of cable for braking resistor,	max m	15	15	15	15	15	15	15
进线电源连接	Line supply connection	L1、L2、L3	螺钉端子						
		电缆截面积 mm <sup>2</sup>	1...2.5	1...2.5	1...2.5	1...2.5	2.5...6	2.5...6	2.5...6
电机连接	Motor connection	U、V、W	螺钉端子						
		电缆截面积 mm <sup>2</sup>	1...2.5	1...2.5	1...2.5	1...2.5	2.5...6	2.5...6	2.5...6
直流母线连接(制动电阻的连接)	DCbus connection (Connection resistor for braking)	DC+、DC-、R	螺钉端子						
		电缆截面积 mm <sup>2</sup>	1...2.5	1...2.5	1...2.5	1...2.5	2.5...6	2.5...6	2.5...6
PE连接	PE connection		外壳上的M4螺钉			M4 screws on the housing	外壳上的M5螺钉		
最大电机电缆长度	Motor cable length, max.	屏蔽电缆 m	50	50	50	50	50	50	50
		非屏蔽电缆 m	100	100	100	100	100	100	100
防护等级	Degree of protection		IP20	IP20	IP20	IP20	IP20	IP20	IP20
外形尺寸	Dimensions	宽(W) mm	80	80	80	80	100	100	100
		高(H) mm	230	230	230	230	291	291	291
		深(D) mm	165	165	165	165	165	165	165
外形尺寸	Dimensions		B1	B1	B1	B1	B2	B2	B2
大约重量	Weight (kg), approx.		1.7	1.7	1.7	1.7	2.8	2.8	2.8

PM25功率模块进线电压380...480V 3AC				PM25 power module incoming voltage 380...480V 3AC					
技术参数		Technical data		A1-PM25-B3C11	A1-PM25-B3C15	A1-PM25-B3C18	A1-PM25-B3C22	A1-PM25-B3C30	A1-PM25-B3C37
额定输出功率	Rated output power	基于(LD) kW	Based on (LD) kW	11	15	18.5	22	30	37
		基于(HD) kW	Based on (HD) kW	7.5	11	15	18.5	22	30
额定输入电流	Rated input current	带进线电抗器 A	With line reactor A	26	33	39	46	63	78
		不带进线电抗器 A	Without line reactor A	32	39	46	53	73	88
额定输出电流	Rated output current	基于(LD) A	Based on (LD) A	26	32	38	45	60	75
		基于(HD) A	Based on (HD) A	18	26	32	38	45	60
额定的载波频率 kHz		Rated carrier frequency kHz		4	4	4	4	4	4
效率 η		Efficiency η		>0.95	>0.95	>0.95	>0.95	>0.95	>0.95
功率损失 kW		Power loss kW		0.4	0.4	0.5	0.7	1	1.3
冷却风量要求 m³/s		Cooling air volume requirement m³/s		0.055	0.055	0.055	0.055	2x0.055	2x0.055
噪声水平 dB(A)		Noise level dB(A)		<40	<40	<40	<40	<50	<50
24V DC输出电源(控制单元用)		24V DC output power supply (to control unit)		1	1	1	1	1	1
制动电阻连接电缆的最大长度 m		Length of cable for braking resistor, max m		15	15	15	15	15	15
进线电源连接	Line supply connection	L1、L2、L3		螺钉端子 Screw terminal					
		电缆截面积 mm²	conductor cross-section: mm²	4...10	4...10	4...10	6...25	6...25	6...25
电机连接	Motor connection	U、V、W		螺钉端子 Screw terminal					
		电缆截面积 mm²	conductor cross-section: mm²	4...10	4...10	4...10	6...25	6...25	6...25
直流母线连接(制动电阻的连接)	DCbus connection (Connection for braking resistor)	DC+、DC-、R		螺钉端子 Screw terminal					
		电缆截面积 mm²	conductor cross-section: mm²	4...10	4...10	4...10	6...25	6...25	6...25
PE连接		PE connection		外壳上的M5螺钉 M5 screws on the housing					
最大电机电缆长度	Motor cable length, max.	屏蔽电缆 m	Shielded (m)	50	50	50	50	50	50
		非屏蔽电缆 m	Unshielded (m)	100	100	100	100	100	100
防护等级		Degree of protection		IP20	IP20	IP20	IP20	IP20	IP20
外形尺寸	Dimensions	宽(W) mm	Width(W) mm	140	140	200	200	200	200
		高(H) mm	Height(H) mm	355	355	472	472	472	472
		深(D) mm	Depth(D) mm	165	165	237	237	237	237
外形尺寸		Dimensions		B3	B3	B4	B4	B4	B4
大约重量 kg		Weight (kg), approx.		7	7	16	16	16	16



PM25功率模块进线电压380...480V 3AC				PM25 power module incoming voltage 380...480V 3AC									
技术参数		Technical data		A1-PM25-B3C45	A1-PM25-B3C55	A1-PM25-B3C75	A1-PM25-B3C90	A1-PM25-B3D11	A1-PM25-B3D13	A1-PM25-B3D16	A1-PM25-B3D20	A1-PM25-B3D25	
额定输出功率	Rated output power	基于(LD) kW	Based on (LD) kW	45	55	75	90	110	132	160	200	250	
		基于(HD) kW	Based on (HD) kW	37	45	55	75	90	110	132	160	200	
额定输入电流	Rated input current	带进线电抗器 A	With line reactor A	86	104	140	172	198	242	245	297	354	
		不带进线电抗器 A	Without line reactor A	78	94	117	154	189	218	297	354	442	
额定输出电流	Rated output current	基于(LD) A	Based on (LD) A	90	110	145	178	205	250	302	370	477	
		基于(HD) A	Based on (HD) A	75	90	110	145	178	205	250	302	370	
	额定的载波频率 kHz		Rated carrier frequency kHz	4	4	4	4	2	2	2	2	2	
	效率 η		Efficiency η	>0.95	>0.95	>0.95	>0.95	>0.95	>0.95	>0.95	>0.95	>0.95	
	功率损失 kW		Power loss kW	1.3	1.67	1.93	2.48	2.3	3.02	3.9	4.4	5.5	
	冷却风量要求 m³/s		Cooling air volume requirement m³/s	0.083	0.083	0.153	0.153	0.153	0.153	0.21	0.21	0.63	
	噪声水平 dB(A)		Noise level dB(A)	<75	<75	<75	<75	<75	<75	<75	<75	<75	
	24V DC输出电源(控制单元用)		24V DC output power supply (to control unit)	1	1	1	1	1	1	1	1	1	
	制动电阻连接电缆的最大长度 m		Length of cable for braking resistor, max m	15	15	15	15	15	15	15	15	15	
进线电源连接	Line supply connection	L1、L2、L3		SC线耳, 用于M10螺栓					SC cable lug, used for M10 bolts		SC线耳, 用于M12螺栓		SC wire ear, used for M12 bolts
		电缆截面积 mm²	conductor cross-section: mm²	35...2x120	35...2x120	35...2x120	35...2x120	35...2x120	35...2x120	2x120	2x120	2x120	
电机连接	Motor connection	U、V、W		SC线耳, 用于M10螺栓					SC cable lug, used for M10 bolts		SC线耳, 用于M12螺栓		SC wire ear, used for M12 bolts
		电缆截面积 mm²	conductor cross-section: mm²	35...2x120	35...2x120	35...2x120	35...2x120	35...2x120	35...2x120	2x120	2x120	2x120	
直流母线连接(制动电阻的连接)	DC bus connection (Connection for braking resistor)	DC+、DC-、R		螺钉端子					Screw terminal		SC线耳, 用于M12螺栓		SC wire ear, used for M12 bolts
		电缆截面积 mm²	conductor cross-section: mm²	25...70	25...70	25...70	25...70	25...70	25...70	2x120	2x120	2x120	
PE连接		PE connection		外壳上的M10螺钉					M10 screws on the housing		外壳上的M8螺钉		M8 screws on the housing
最大电机电缆长度	Motor cable length, max.	屏蔽电缆 m	Shielded (m)	50	50	50	50	50	50	300	300	300	
		非屏蔽电缆 m	Unshielded (m)	100	100	100	100	100	100	100	100	100	
防护等级		Degree of protection		IP20	IP20	IP20	IP20	IP20	IP20	IP20	IP20	IP20	
外形尺寸	Dimensions	宽(W) mm	Width(W) mm	305	305	305	305	305	305	536	536	536	
		高(H) mm	Height(H) mm	750	750	750	750	750	750	885	885	885	
		深(D) mm	Depth(D) mm	357	357	357	357	357	357	370	370	370	
外形尺寸		Dimensions		B6	B6	B6	B6	B6	B6	B7	B7	B7	
大约重量 kg		Weight (kg), approx.		65	65	65	65	65	65	150	150	150	

## 2.5 特性曲线

降容数据·脉冲频率

## 2.5 Characteristic curve

Capacity reduction data & Impulse frequency

驱动器功率 (kW)	Drivers power	不同载波下 驱动器输出 电流(A)				Output current under different carriers (A)
		2kHz	4kHz	6kHz	8kHz	
0.75		2.2	2.2	1.9	1.5	
1.5		4.1	4.1	3.5	2.9	
2.2		5.9	5.9	5	4.1	
3		7.7	7.7	6.5	5.4	
4		10.2	10.2	8.7	7.1	
5.5		13.2	13.2	11.2	9.2	
7.5		18	18	15.3	12.6	
11		26	26	22.1	18.2	
15		32	32	27.2	22.4	
18.5		38	38	32.3	26.6	
22		45	45	38.3	31.5	
30		60	60	51	42	
37		75	75	63.8	52.5	
45		110	90	76.5	63	
55		130	110	93.5	77	
75		178	145	123.3	101.5	
90		200	178	151.3	124.6	
110		205	178			
132		250	202			
160		302	250			
200		370	302			
250		477	370			

降容数据·环境温度

Capacity reduction data & Environment temperature

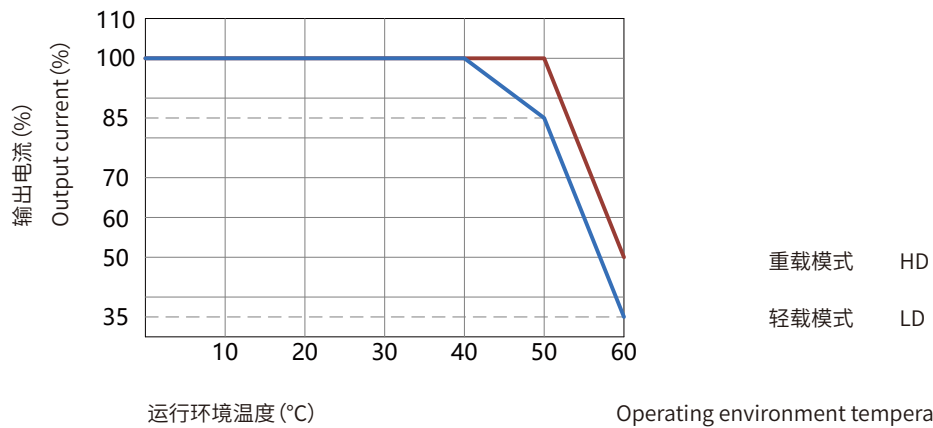

降容数据·海拔高度

Capacity reduction data & Installation altitude

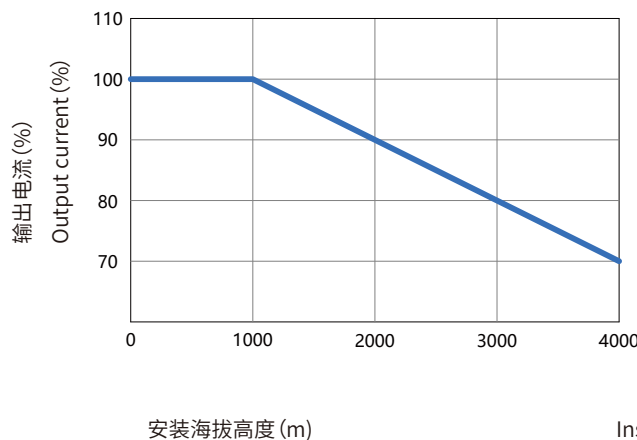

## 2.6 外形尺寸

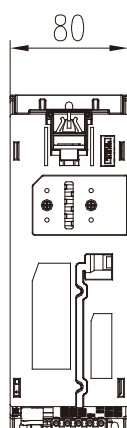
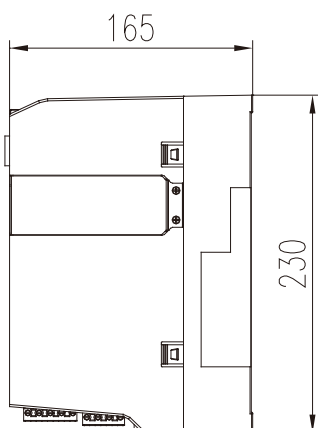

## 2.6 Dimensions



PM25功率模块B1外形尺寸图,单位为mm  
 固定需要3个M4组合螺钉,3个M4螺母,拧紧力矩:2.5Nm  
 顶部和底部所需的通风空间:100mm,侧面无需通风空间  
 当安装了控制模块时,安装深度相应增加

PM25 Power Module B1's dimensions (Unit:mm)  
 Fixing requires 3 M4 combination screws, 3 M4 nuts, tightening torque: 2.5Nm  
 Ventilation space at the top and bottom: 100mm, no need on the side.  
 After installing the control module,the installation depth increases accordingly.

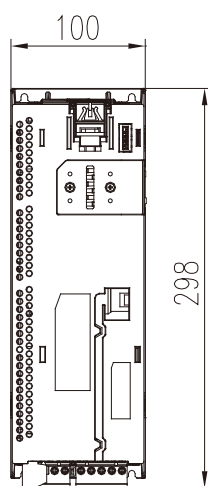
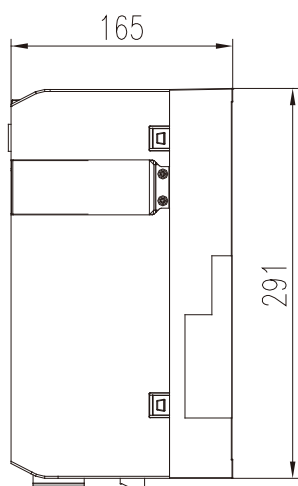

PM25功率模块B2外形尺寸图,单位为mm  
 固定需要4个M4组合螺钉,4个M4螺母,拧紧力矩:2.5Nm  
 顶部和底部所需的通风空间:100mm,侧面无需通风空间  
 当安装了控制模块时,安装深度相应增加

PM25 Power Module B2's dimensions (Unit:mm)  
 Fixing requires 4 M4 combination screws, 4 M4 nuts, tightening torque: 2.5Nm  
 Ventilation space at the top and bottom: 100mm, no need on the side.  
 After installing the control module,the installation depth increases accordingly.

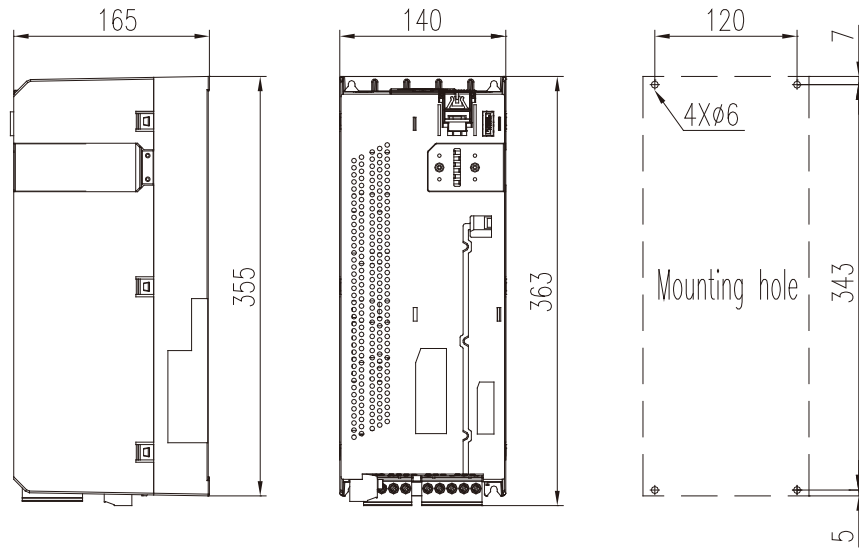

PM25功率模块B3外形尺寸图,单位为mm  
 固定需要4个M5组合螺钉,4个M5螺母,拧紧力矩:4Nm  
 顶部和底部所需的通风空间:100mm,侧面  
 无需通风空间  
 当安装了控制模块时,安装深度相应增加

PM25 Power Module B3's dimensions  
 (Unit:mm)  
 Fixing requires 4 M5 combination screws, 4 M5  
 nuts, tightening torque: 4Nm  
 Ventilation space at the top and bottom:  
 100mm, no need on the side.  
 After installing the control module,the  
 installation depth increases accordingly.

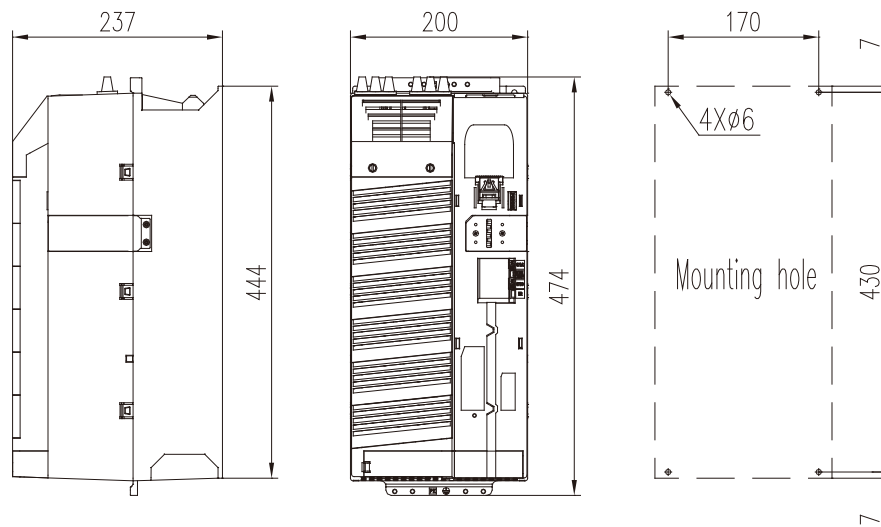

PM25功率模块B4外形尺寸图,单位为mm  
 固定需要4个M5组合螺钉,4个M5螺母,拧紧力矩:6Nm  
 顶部和底部所需的通风空间:100mm,侧面  
 无需通风空间  
 当安装了控制模块时,安装深度相应增加

PM25 Power Module B4's dimensions  
 (Unit:mm)  
 Fixing requires 4 M5 combination screws, 4 M5  
 nuts, tightening torque: 6Nm  
 Ventilation space at the top and bottom:  
 100mm, no need on the side.  
 After installing the control module,the  
 installation depth increases accordingly.

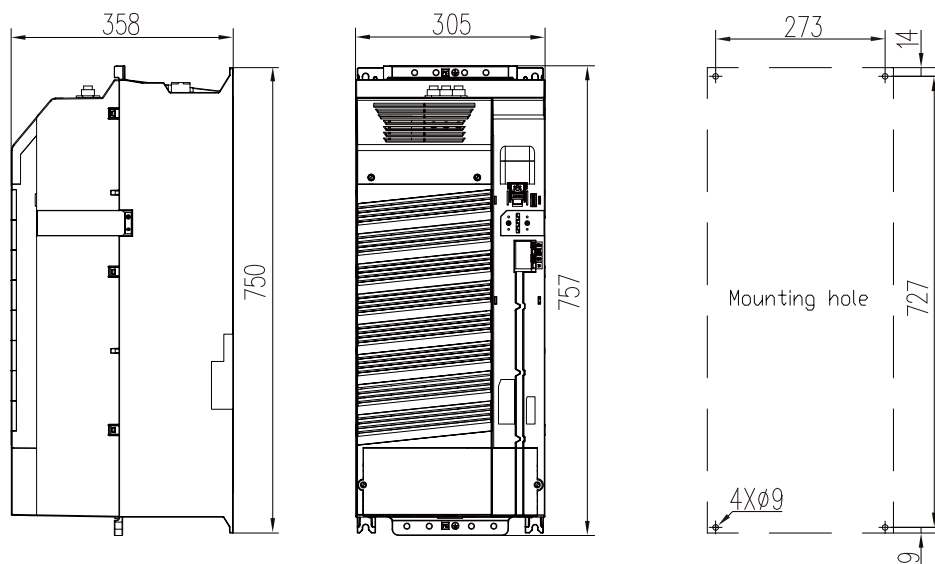

PM25功率模块B6外形尺寸图,单位为mm  
 固定需要4个M8组合螺钉,4个M8螺母,拧紧力矩:25Nm  
 顶部和底部所需的通风空间:100mm,侧面无需通风空间  
 当安装了控制模块时,安装深度相应增加

PM25 Power Module B6's dimensions (Unit:mm)  
 Fixing requires 4 M8 combination screws, 4 M8 nuts, tightening torque: 25Nm  
 Ventilation space at the top and bottom: 100mm, no need on the side.  
 After installing the control module, the installation depth increases accordingly.

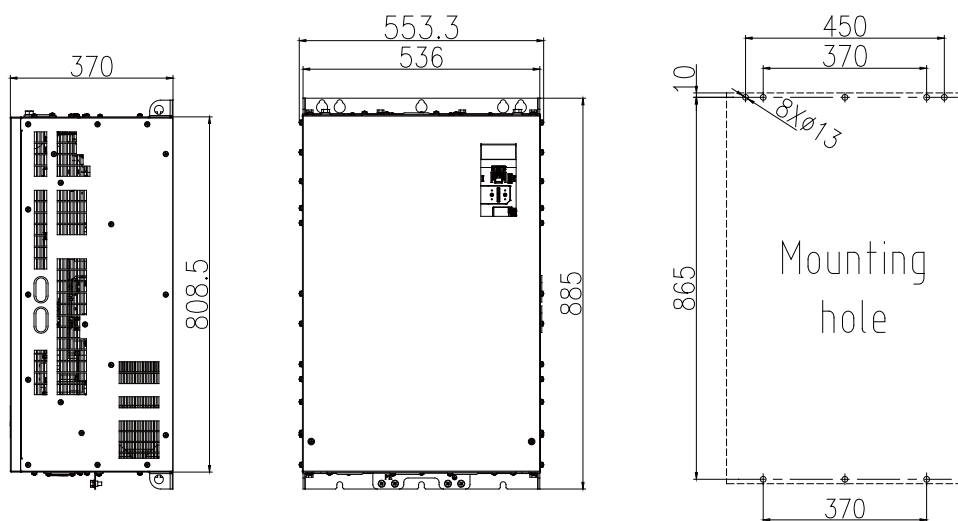

PM25功率模块B7外形尺寸图,单位为mm  
 固定需8个M12组合螺钉,8个M12螺母,拧紧力矩:80Nm  
 顶部和底部所需空间:200mm  
 两侧所需空间:100mm

PM25 Power Module B7's dimensions (Unit:mm)  
 Fixing requires 8 M12 combination screws, 8 M12 nuts, tightening torque: 80Nm  
 Ventilation space at the top and bottom: 200mm  
 Ventilation space on the both sides: 100mm

## 2.7 可选件

### ◆ 屏蔽端接组件

屏蔽端接组件不仅可以消除机械应力,还可以使得电源和控制电缆的屏蔽层连接更加简单,从而保证有更好的EMC效果。

屏蔽端接组件订货数据

外形尺寸	Dimensions	型号	Model
B1		A1-H06-B1	
B2			
B3		A1-H06-B3	
B4		A1-H06-B4	
B6		A1-H06-B6	

屏蔽端接组件图和整机外形尺寸图

### ◆ B1(B2括号内尺寸)

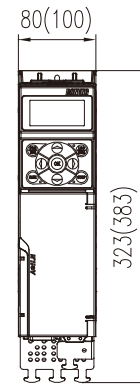
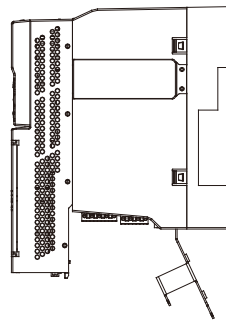
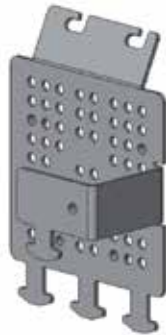

### ◆ B3

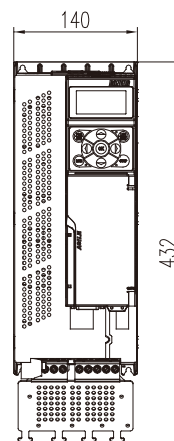
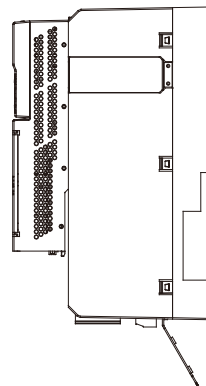

## 2.7 Options

### ◆ Shield termination components

The shield termination components can not only eliminate mechanical stress, but also make it easier to connect the shielding layer of control cable and power supply, so as to ensure better EMC effect.

Ordering data for shield termination components

Shield termination components diagram and dimensions

### ◆ B1(B2 dimensions in parentheses)

### ◆ B3

◆ B4

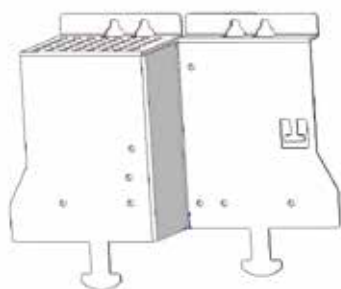

◆ B4

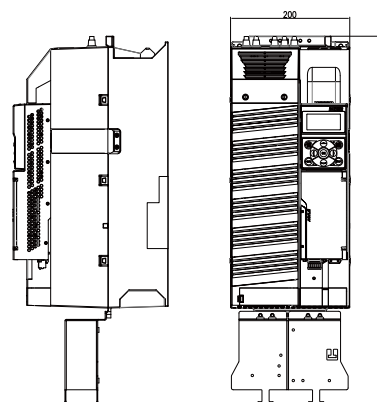

◆ B6

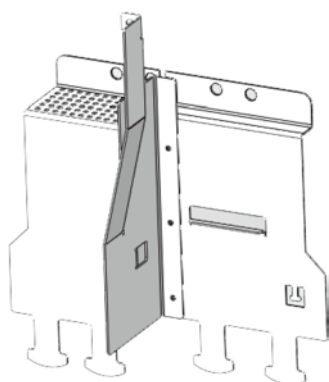

◆ B6

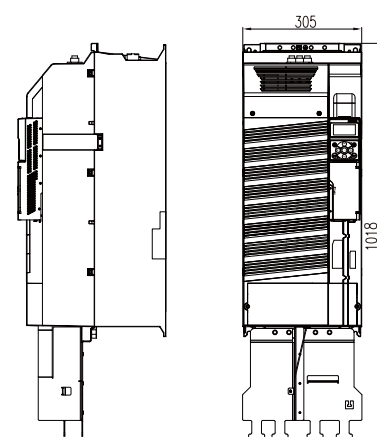

● 键盘柜门安装组件

键盘柜门安装组件可以方便的将键盘安装在柜门上,在不打开柜门的前提下可操作驱动器。  
键盘柜门安装组件订货数据

● Keyboard cabinet door installation components

The keyboard cabinet door installation component can conveniently install the keyboard on the cabinet door, and can operate the driver without opening the cabinet door.  
Ordering data of keyboard cabinet door installation components

电缆长度(m)	Cable length (m)	IP等级	IP level	型号	Model
1.5		54		A1- H15-P- B15	
2.0		54		A1- H15-P- B20	
3.0		54		A1- H15-P- B30	
5.0		54		A1- H15-P- B50	

键盘柜门安装组件外形及柜门开孔尺寸图

Outline drawing of keyboard cabinet door installation components and opening dimensions of cabinet door

外形图 Outline drawing

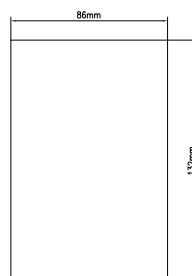

柜门开孔尺寸图 Dimensions of cabinet door opening

### 可选配件

● 进线电抗器

当系统的故障率高时,需要加装进线电抗器以保护驱动器不受过大的谐波电流的干扰,改善驱动器的输入侧功率因数;防止过载,并将进线谐波限制在允许的值内,以确保驱动器达到期望的使用寿命。400V 50/60Hz A1系列驱动器可选的进线电抗器推荐型号如下表:

### Optional accessories

● Line reactor

When the system failure rate is high, it is necessary to install a line reactor to protect the driver from excessive harmonic currents, improve the input side power factor of the driver, prevent overload, and limit the line harmonics to allowable values to ensure that the driver reaches the desired life. The recommended models of optional line reactors for 400V 50 / 60Hz A1 series drivers are as follows:

驱动器 Driver		进线电抗器 推荐参数 Recommended parameters of line reactor		订货号 Ordering data
框架 Frame	无内置滤波器型号 Model without built-in filter	额定 电流 Rated current (A)	电感 Inductance (mH)	
B1	A1-PM25-B3A75-N	2.6	5.9	A1-H12-TB280
	A1-PM25-B3B15-N	4.9	3.1	A1-H12-TB280
	A1-PM25-B3B22-N	7.1	2.2	A1-H12-TB200
	A1-PM25-B3B30-N	9.2	1.7	A1-H12-TB140
B2	A1-PM25-B3B40-N	12.2	1.3	A1-H12-TA930
	A1-PM25-B3B55-N	15.8	1	A1-H12-TA700
	A1-PM25-B3B75-N	21.6	0.8	A1-H12-TA700
B3	A1-PM25-B3C11-N	31.2	0.5	A1-H12-TA470
	A1-PM25-B3C15-N	38.4	0.4	A1-H12-TA350
B4	A1-PM25-B3C18-N	45.6	0.5	A1-H12-TA280
	A1-PM25-B3C22-N	54	0.4	A1-H12-TA240
	A1-PM25-B3C30-N	72	0.3	A1-H12-TA160
	A1-PM25-B3C37-N	90	0.2	A1-H12-TA160
B6	A1-PM25-B3C45-N	120	0.117	A1-H12-TB120
	A1-PM25-B3C55-N	150	0.094	A1-H12-TA095
	A1-PM25-B3C75-N	200	0.07	A1-H12-TA070
	A1-PM25-B3C90-N	250	0.056	A1-H12-TA056
	A1-PM25-B3D11-N	250	0.056	A1-H12-TA056
	A1-PM25-B3D13-N	290	0.048	A1-H12-TA048
B7	A1-PM25-B3D16-N	330	0.042	A1-H13-TA042
	A1-PM25-B3D20-N	390	0.036	A1-H13-TA036
	A1-PM25-B3D25-N	490	0.028	A1-H13-TA028



● 进线滤波器

进线滤波器的作用是抑制驱动器通过输入电源线所传输到公共电网中的电磁干扰,同时也衰减从电源线进入驱动器的干扰;在安装时请尽量靠近驱动器的输入端子侧进行安装,请使用驱动器专用的进线滤波器。400V 50/60Hz A1系列驱动器可选的进线滤波器推荐型号如下表:

● Line filter

The function of the line filter is to suppress the electromagnetic interference transmitted from the driver to the public power grid through the input power line, and also to attenuate the interference from the power line into the driver; Please install as close to the input terminal side of the driver as possible, use the driver-specific line filter. The recommended models of optional line filters for 400V 50 / 60Hz A1 series drivers are as follows:

驱动器		Driver	EMC 滤波器	EMC filter	订货号	Ordering data
框架	Frame	无内置滤波器型号 Model without built-in filter	额定电流 (A)	Rated current		
B1		A1-PM25-B3A75-N	2.9		A1-H11-A-C10	
		A1-PM25-B3B15-N	5.5		A1-H11-A-C10	
		A1-PM25-B3B22-N	7.7		A1-H11-A-C10	
		A1-PM25-B3B30-N	10.1		A1-H11-A-C10	
B2		A1-PM25-B3B40-N	13.3		A1-H11-A-C20	
		A1-PM25-B3B55-N	17.2		A1-H11-A-C20	
		A1-PM25-B3B75-N	22.2		A1-H11-A-C30	
B3		A1-PM25-B3C11-N	32.6		A1-H11-A-C36	
		A1-PM25-B3C15-N	39.9		A1-H11-A-C50	
B4		A1-PM25-B3C18-N	36		A1-H11-A-C50	
		A1-PM25-B3C22-N	42		A1-H11-A-C50	
		A1-PM25-B3C30-N	57		A1-H11-A-C65	
		A1-PM25-B3C37-N	70		A1-H11-A-C80	
B6		A1-PM25-B3C45-N	100		A1-H11-A-D10	
		A1-PM25-B3C55-N	130		A1-H11-A-D13	
		A1-PM25-B3C75-N	150		A1-H11-A-D15	
		A1-PM25-B3C90-N	180		A1-H11-A-D18	
		A1-PM25-B3D11-N	200		A1-H11-A-D20	
		A1-PM25-B3D13-N	250		A1-H11-A-D25	
B7		A1-PM25-B3D16-N	300		A1-H11-A-D30	
		A1-PM25-B3D20-N	400		A1-H11-A-D40	
		A1-PM25-B3D25-N	500		A1-H11-A-D50	

● 出线电抗器

当驱动器和电机之间的距离超过50米时,由于长电缆对地的寄生电容效应导致漏电流过大,驱动器容易频繁发生过流保护,同时为了避免电机绝缘损坏,须加输出电抗器补偿,输出电抗器可以减小电机绕组上的电压负载,以及采用长的电机电缆时,容性充放电电流加在功率部分的附加负载。400V 50/60Hz A1系列驱动器可选的输出电抗器推荐型号如下表:

● Output reactor

When the distance between the driver and the motor exceeds 50 meters, the leakage current is too large due to the parasitic capacitance effect of the long cable to the ground, and the driver is prone to frequent overcurrent protection. At the same time, to avoid damage to the motor insulation, output reactor compensation is required. The output reactor can reduce the voltage load on the motor windings, and when a long motor cable is used, the capacitive charge and discharge current is added to the additional load of the power section. The recommended models of optional output reactors for 400V 50 / 60Hz A1 series drivers are as follows:

驱动器 Driver		输出电抗器 Output reactor		订货号 Ordering data
框架 Frame	无内置滤波器型号 Model without built-in filter	额定电流 Rated current	电感 Inductance	
		(A)	(mH)	
B1	A1-PM25-B3A75-N	2.6	3.2	A1-H13-TB140
	A1-PM25-B3B15-N	4.9	1.7	A1-H13-TB140
	A1-PM25-B3B22-N	7.1	1.2	A1-H13-TB100
	A1-PM25-B3B30-N	9.2	0.9	A1-H13-TA700
B2	A1-PM25-B3B40-N	12.2	0.7	A1-H13-TA470
	A1-PM25-B3B55-N	15.8	0.5	A1-H13-TA350
	A1-PM25-B3B75-N	21.6	0.4	A1-H13-TA230
B3	A1-PM25-B3C11-N	31.2	0.3	A1-H13-TA180
	A1-PM25-B3C15-N	38.4	0.2	A1-H13-TA180
B4	A1-PM25-B3C18-N	45.6	0.2	A1-H13-TA140
	A1-PM25-B3C22-N	54	0.2	A1-H13-TA120
	A1-PM25-B3C30-N	72	0.1	A1-H13-TA087
	A1-PM25-B3C37-N	90	0.1	A1-H13-TA078
B6	A1-PM25-B3C45-N	120	0.058	A1-H13-TA058
	A1-PM25-B3C55-N	150	0.047	A1-H13-TA047
	A1-PM25-B3C75-N	200	0.035	A1-H13-TA035
	A1-PM25-B3C90-N	250	0.028	A1-H13-TA028
	A1-PM25-B3D11-N	250	0.028	A1-H13-TA028
	A1-PM25-B3D13-N	290	0.024	A1-H13-TA024
B7	A1-PM25-B3D16-N	330	0.021	A1-H13-TA021
	A1-PM25-B3D20-N	390	0.018	A1-H13-TA018
	A1-PM25-B3D25-N	490	0.014	A1-H13-TA014

● 制动电阻

制动电阻用于使大转动惯量的负载迅速制动。在电机和负载制动时，动能转换成的再生电能会返回到驱动器中，直流母线电压因此抬高，驱动器将这些再生的能量几乎全部消耗在制动电阻上；400V 50/60Hz A1系列驱动器可选的制动电阻推荐规格如下：

● Braking resistance

The braking resistor is used to quickly brake a load with large moment of inertia. When the motor and load are braked, the regenerative energy converted from kinetic energy will be returned to the driver, and the DC bus voltage will be raised. The driver will consume almost all of this regenerated energy on the braking resistor; The recommended models of optional braking resistor 400V 50 / 60Hz A1 series drivers are as follows:

驱动器 Driver		允许的最小制动电阻 Allowable minimum braking resistance	推荐值 Recommended value		10% ED (100s 周期) 的非频繁制动应用场合	10% ED (100s cycle) infrequent braking applications
框架 Frame	无内置滤波器型号 Model without built-in filter		功率 Power (kW)	阻值 Resistance (Ω)	博能型号 BONENG Model	
					订货号 Ordering data	等效制动电阻 Equivalent braking resistance
B1	A1-PM25-B3A75-N	374Ω	0.1	750	A1-H02-A10-K-D75	100W 750Ω
	A1-PM25-B3B15-N	374Ω	0.2	390	A1-H02-A20-K-D39	200W 390Ω
	A1-PM25-B3B22-N	140Ω	0.3	240	A1-H02-A40-K-D24	400W 240Ω
	A1-PM25-B3B30-N	140Ω	0.5	180	A1-H02-A50-K-D18	500W 180Ω
B2	A1-PM25-B3B40-N	75Ω	0.6	130	A1-H02-A80-K-D13	800W 130Ω
	A1-PM25-B3B55-N	75Ω	0.8	100	A1-H02-A80-K-D10	800W 100Ω
	A1-PM25-B3B75-N	75Ω	1.1	75	A1-H02-B12-K-C75	1200W 75Ω
B3	A1-PM25-B3C11-N	30Ω	1.6	51	A1-H02-B20-K-C51	2000W 51Ω
	A1-PM25-B3C15-N	30Ω	2.2	36	A1-H02-B25-K-C36	2500W 36Ω
B4	A1-PM25-B3C18-N	27Ω	2.7	30	A1-H02-B30-K-C30	3000W 30Ω
	A1-PM25-B3C22-N	27Ω	2.9	28	A1-H02-B30-K-C28	3000W 28Ω
	A1-PM25-B3C30-N	15Ω	4.4	18.2	A1-H02-B50-K-C18	5000W 18.2Ω
	A1-PM25-B3C37-N	15Ω	5.4	15	A1-H02-B60-K-C15	6000W 15Ω
B6	A1-PM25-B3C45-N	10Ω	6.7	12	A1-H02-B80-K-C12	8000W 12Ω
	A1-PM25-B3C55-N	10Ω	8	10	A1-H02-B80-K-C10	8000W 10Ω
	A1-PM25-B3C75-N	7.1Ω	11	7.3	A1-H02-C12-K-B73	12000W 7.3Ω
	A1-PM25-B3C90-N	7.1Ω	11	7.3	A1-H02-C12-K-B73	12000W 7.3Ω
	A1-PM25-B3D11-N	5Ω	16	5	A1-H02-C20-K-B50	20000W 5Ω
	A1-PM25-B3D13-N	5Ω	16	5	A1-H02-C20-K-B50	20000W 5Ω

注：  
B7功率模块推荐选用外置制动单元的功率为驱动器额定功率的20%，根据选用的外置制动单元选择制动电阻。

Note:  
For Power Module B7, you require an external brake unit and 20% of the inverter power, the braking resistor according to the external brake unit.

驱动器 Driver		15% ED 的频繁制动应用 15% ED frequent braking applications (例如：行车平移应用)				25% ED 的频繁制动应用场合 25% ED frequent braking applications (例如：行车提升应用)			
		推荐值 Recommended value		博能型号 BONENG Model		推荐值 Recommended value		博能型号 BONENG Model	
框架 Frame	无内置滤波器型号 Model without built-in filter	功率 Power (kW)	阻值 Resistance (Ω)	订货号 Ordering number	等效制动电阻 Equivalent braking resistance	功率 Power (kW)	阻值 Resistance (Ω)	订货号 Ordering number	等效制动电阻 Equivalent braking resistance
		B1	A1-PM25-B3A75-N	0.2	750	A1-H02-A20-K-D75	200W 750Ω	0.37	750
A1-PM25-B3B15-N	0.4		390	A1-H02-A40-K-D39	400W 390Ω	0.75	390	A1-H02-A80-K-D39	800W 390Ω
A1-PM25-B3B22-N	0.6		240	A1-H02-A80-K-D24	800W 240Ω	1.1	240	A1-H02-B12-K-D24	1200W 240Ω
A1-PM25-B3B30-N	0.9		180	A1-H02-B10-K-D18	1000W 180Ω	1.5	180	A1-H02-B15-K-D18	1500W 180Ω
B2	A1-PM25-B3B40-N	1.2	130	A1-H02-B12-K-D13	1200W 130Ω	2	130	A1-H02-B20-K-D13	2000W 130Ω
	A1-PM25-B3B55-N	1.6	100	A1-H02-B20-K-D10	2000W 100Ω	2.7	102	A1-H02-B30-K-D10	3000W 102Ω
	A1-PM25-B3B75-N	2.2	75	A1-H02-B25-K-C75	2500W 75Ω	3.7	78	A1-H02-B40-K-C78	4000W 78Ω
B3	A1-PM25-B3C11-N	3.3	48	A1-H02-B40-K-C48	4000W 48Ω	5.5	51	A1-H02-B60-K-C51	6000W 51Ω
	A1-PM25-B3C15-N	4.5	36	A1-H02-B50-K-C36	5000W 36Ω	7.5	36	A1-H02-B80-K-C36	8000W 36Ω
B4	A1-PM25-B3C18-N	5.5	30	A1-H02-B60-K-C30	6000W 30Ω	9	30	A1-H02-C10-K-C30	10000W 30Ω
	A1-PM25-B3C22-N	6.6	27	A1-H02-B80-K-C22	8000W 27Ω	11	28.7	A1-H02-C12-K-C28	12000W 28.7Ω
	A1-PM25-B3C30-N	9	18	A1-H02-C10-K-C18	10000W 18Ω	15	18	A1-H02-C15-K-C18	15000W 18Ω
	A1-PM25-B3C37-N	11	16	A1-H02-C12-K-C16	12000W 16Ω	18	16.5	A1-H02-C20-K-C16	20000W 16.5Ω
B6	A1-PM25-B3C45-N	13	12	A1-H02-C15-K-C12	15000W 12Ω	22	13.2	A1-H02-C25-K-C13	25000W 13.2Ω
	A1-PM25-B3C55-N	16	10	A1-H02-C16-K-C10	16000W 10Ω	27	11	A1-H02-C30-K-C11	30000W 11Ω
	A1-PM25-B3C75-N	22	8	A1-H02-C25-K-B80	25000W 8Ω	37	8.3	A1-H02-C40-K-B83	40000W 8.3Ω
	A1-PM25-B3C90-N	27	7.3	A1-H02-C30-K-B73	30000W 7.3Ω	45	7.3	A1-H02-C45-K-B73	45000W 7.3Ω
	A1-PM25-B3D11-N	33	5.1	A1-H02-C35-K-B51	35000W 5.1Ω	55	5.1	A1-H02-C55-K-B60	55000W 6Ω
	A1-PM25-B3D13-N	39	5	A1-H02-C40-K-B50	40000W 5Ω	66	5	A1-H02-C70-K-B50	70000W 5Ω

### 3 CM25控制模块

### 3 CM25 Control Module

#### 3.1 概述

#### 3.1 Summary



CM25控制模块举例

CM25 Control Module

CM25控制模块为驱动器提供闭环控制功能，作为通用功能设计，既可以提供V/f控制，也可以实现矢量控制。

这里，有以下几点需要注意：

- ◆ 闭环矢量控制 (FVC) 和无感矢量控制 (SVC) 都可以实现
- ◆ 工艺功能不断开发 (已推出“防摇摆”功能，“随载适速”功能.....)

CM25 control module provides closed-loop control function for the driver. It can be used to implement all common applications involving V/F or sector control .

These points must be noted:

- ◆ Vector control (FVC) and Sensorless vector control(SVC) can both be achieved
- ◆ Continuous development of process functions. (Has introduced "Anti-swing"; "Speed with load" function, etc.)

## 3.2 选型订货数据

型号表示方法

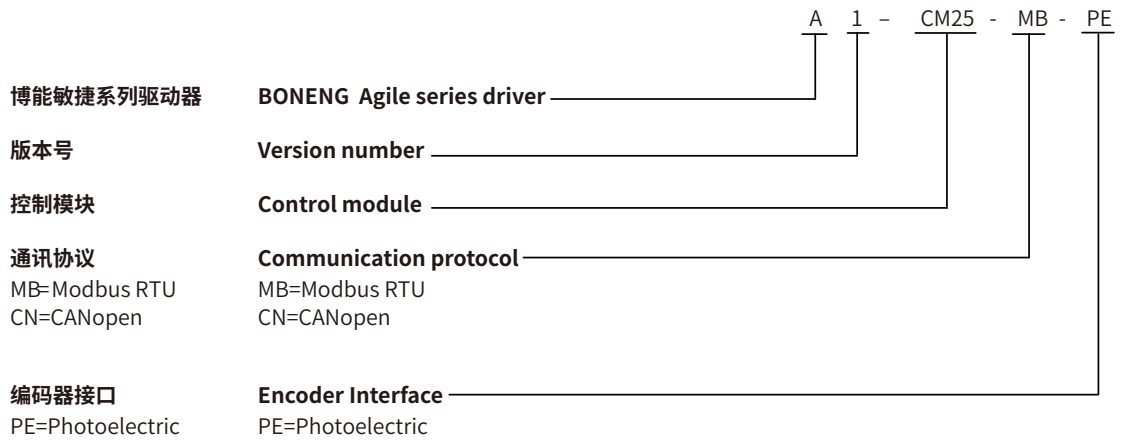

订货数据

Ordering Data

接口类型描述	Interface type description	
支持Modbus通讯协议、增量/绝对式光电编码器	Support Modbus communication protocol, Incremental/absolute photoelectric encoder	A1-CM25-MB-PE
支持CANopen通讯协议、增量/绝对式光电编码器	Support CANOPEN communication protocol, Incremental/absolute photoelectric encoder	A1-CM25-CN-PE

## 3.3 设计

## 3.3 Design



CM25控制模块端子盖打开和闭合图

CM25 Control Module's terminal cover (open and closed)

## 设计(续)

## Design (continued)

功能	Functions			技术数据	Technical data
通讯功能	Communication functions	A1-CM25-MB	A1-CM25-MB	•支持Modbus RTU	• Support for Modbus RTU
		A1-CM25-CN	A1-CM25-CN	•支持CANopen	• Support for CANopen
外部电源供应	External power supply	通过端子+24VIN和GNDIN提供18~30Vdc, 最大工作电流2A。当电流超过4A, 切断电路。		Supply 18~30Vdc through terminal+24V IN and GND IN.The maximum operating current is 2A. The circuit will be cut off when the current exceeds 4A.	
输出电源	Output power	数字输入端子电源	Digital input terminal power	18Vdc~30Vdc, 最大200mA	18Vdc~30Vdc, the maximum is 200mA
		模拟输入端子电源	Analog input terminal power	9.5Vdc~10.5Vdc, 最大40mA	9.5Vdc~10.5Vdc, the maximum is 40mA
		编码器电源	Encoder power	4.75Vdc~30Vdc, 最大350mA	4.75Vdc~30Vdc, the maximum is 350mA
数字量输入	Digital inputs	7个普通共COM输入	7 common COM inputs	•DI 0~DI 6	•DI 0~DI 6
				•电气隔离	• Electrical isolation
				•支持双向输入	• Support for two-way input
		1个普通差分输入	1 common differential input	•DI 7	•DI 7
		•电气隔离	• Electrical isolation		
		•支持双向输入	• Support for two-way input		
		2个高速差分输入	2 high-speed differential inputs	•DI 8~DI 9	•DI 8~DI 9
				•电气隔离	• Electrical isolation
				•支持双向输入	• Support for two-way input
模拟量输入	Analog inputs	2个通道 (AI 0和AI1)	2 channels(AI0 and AI1)	•差分输入 •可选择0~10V、-10~+10V、0~20mA和4~20mA •0~20mA时输入阻抗为500ohm	• Differential input • Options:0~10V、-10~+10V,0~20mA and 4~20mA • The input impedance is 500 ohms at 0~20mA.
数字量输出	Digital outputs	2个继电器输出	2 relay outputs	•DO 0~DO 1	•DO 0~DO 1
		2个晶体管输出	2 transistor outputs	•最大30Vdc和0.5A •DO 2~DO 3 •每个输出最大0.05A •开集电极方式	• The maximum is 30Vdc and 0.5A •DO 2~DO 3 • Maximum 0.05A per output • Open collector mode
模拟量输出	Analog outputs	2个通道 (AO 0和AO1)	2 channels(AO0 and AO1)	•可选择0~10V,0~20mA和4~20mA •参考电位为GND	• Options :0~10V,0~20mA and4~20mA • The reference potential is GND
温度侦测	Temperature detection	PTC	PTC	•最小侦测值为22ohm •最大侦测值为2499ohm	• The minimum measured value is 22 ohm • The maximum measured value is 2499 ohm
		KTY84	KTY84	•最小侦测值为22ohm •最大侦测值为2499ohm	• The minimum measured value is 22 ohm • The maximum measured value is 2499 ohm
编码器	Encoder	HTL, TTL	HTL, TTL	•最大频率500kHz •支持推挽和开集电极编码器 •支持5V和24V二种电源 •电源最大输出350mA	• The maximum frequency is 500kHz • Support for push-pull and open collector encoder. • Support both 5V and 24V power supply • The maximum power output is 350mA
指示灯	Indicator lights	2个双色指示	2 dichromatic indications	•RDY指示灯, 红绿双色 •BF指示灯, 红绿双色	• RDY indicator light, red and green • BF indicator light, red and green
		3个单色指示	3 monochromatic indications	•SAFE指示灯, 黄色 •LNK1指示灯, 绿色 •LNK2指示灯, 绿色	• SAFE indicator light, yellow • LNK1 indicator light, green • LNK2 indicator light, green
PC接口	PC interface	Mini-B, 不支持OTG	Mini-B,OTG not supported		
存储卡接口	Memory card interface	支持SD卡	Support for SD card		
电磁兼容性	Electromagnetic compatibility	符合标准IEC 61800-3	In accordance with the standard IEC 61800-3		
工作温度	Operating temperature	-20°C~+50°C	-20°C~+50°C		
储存温度	Storage temperature	-40°C~+70°C	-40°C~+70°C		
空气湿度	Air humidity	<95%, 不允许有凝露	<95%, no condensation		

3.4 电气连接

3.4 Electrical connection

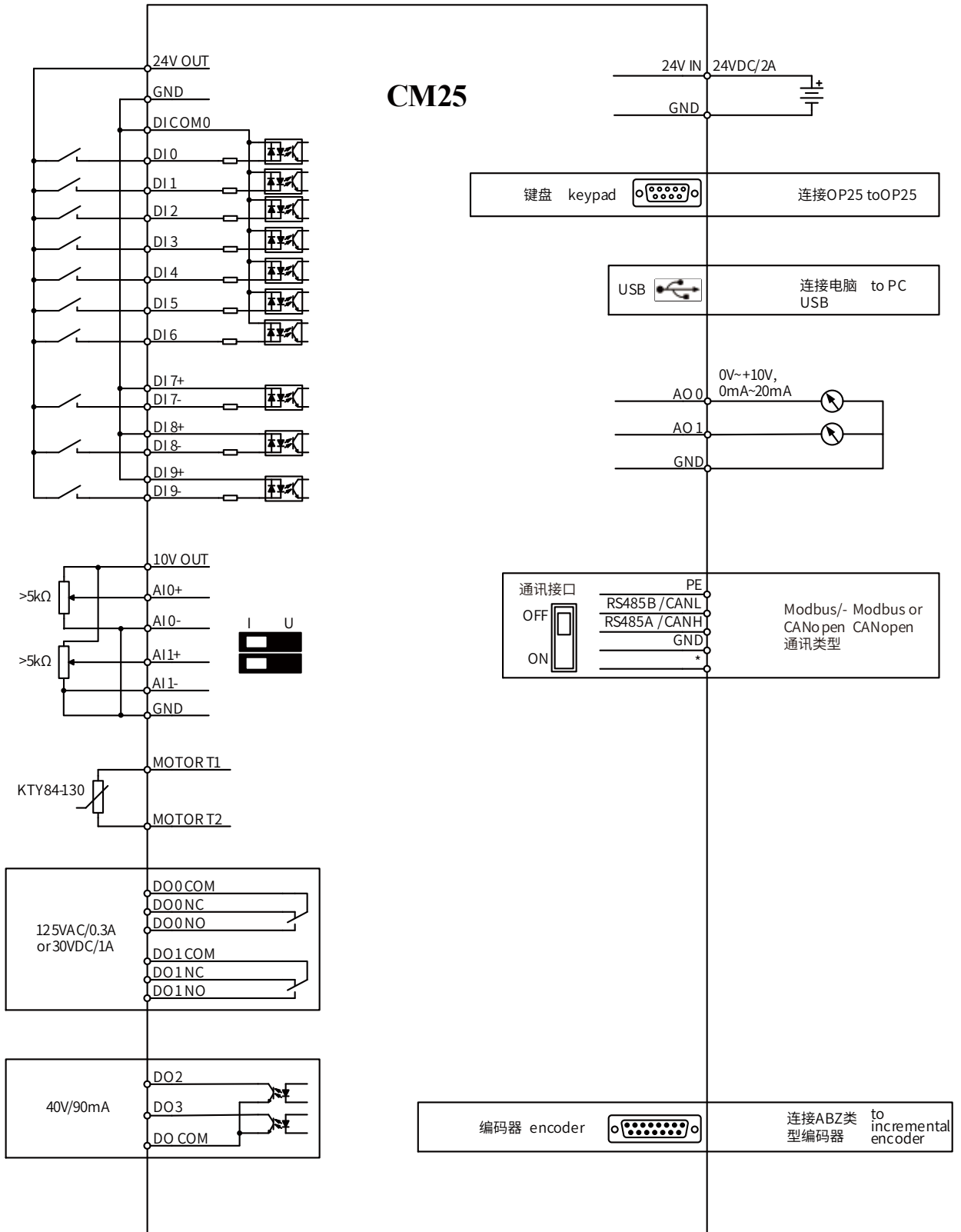



DB15编码器接口

DB15 encoder interface

引脚	Pin number	信号名称	Signal name	信号说明	Description
1		-		-	
2		-		-	
3		-		-	
4		DB15_PWR		5V/24V	
5		DB15_PWR		5V/24V	
6		-		-	
7		DB15_0V		0V	
8		DB15_0V		0V	
9		-		-	
10		DB15_Z+		Z+	
11		DB15_Z-		Z-	
12		DB15_B-		B-	
13		DB15_B+		B+	
14		DB15_A-		A-	
15		DB15_A+		A+	

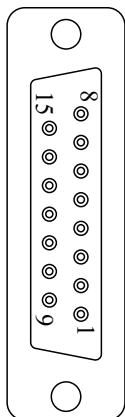

### 3.5 技术参数

### 3.5 Technical parameters

		电气参数	Electrical parameter
工作电压	Operating voltage	通过功率单元的24VDC 或外接20~30VDC电源	Connecting 24V DC through the power unit or 20~30VDC supplied from external power.
最大电流消耗	The maximum current consumption	≤1.0A	≤1.0A
保护隔离	Protection isolation	PELV 按照 EN50178 标准	PELV in accordance with the standard EN50178
		保护与进线电源分开, 采用 双重增强的隔离	The protection is separated from the incoming power supply, with double enhanced isolations.
功率损失	Power loss	≤10W	≤10W
		接口	interfaces
普通的数字量输入	Common digital inputs	7个共COM输入	7 common COM inputst
		•DI0~DI6	•DI0~DI6
		•电气隔离	•Electrical isolation
		•支持双向输入	•Support for two-way input
		1个普通差分输入	1 common differential input
		•DI7	•DI7
		•电气隔离	•Electrical isolation
		•支持双向输入	•Support for two-way input
		2个高速差分输入	2 high-speed differential inputs
		•DI8~DI9	•DI8~DI9
		•电气隔离	•Electrical isolation
		•支持双向输入	•Support for two-way input
安全的数字量输入	Safety digital inputs	最多3路输入	3 inputs at most
		•复用6路普通DI端子, DI0~DI5	•Reuse 6-way common DI terminals,DI0~DI5
模拟量输入	Analog inputs	2通道输入 (AI0~AI1)	2 channels(AI0 and AI1)
		•差分输入	•Differential input
		•可选择0~10V, -10~ 10V或者0~20mA	•Options :0~10V, -10~ +10V and 0~20mA
		•0~20mA时输入阻抗为 500Ω	•The input impedance is 500 ohm at 0~20mA.
数字量输出	Digital outputs	2通道继电器输出	2 relay outputs
		•DO0~DO1	•DO0~DO1
		•最大30VDC输出和0.5A	•The maximum output is 30Vdc and 0.5A
		2通道晶体管输出	2 transistor outputs
		•DO2~DO3	•DO2~DO3
		•最大0.05A输出	•The maximum output is 0.05A
模拟量输出	Analog outputs	2通道输出 (AO0~AO1)	2 outputs (AO0~AO1)
		•可选择0~10V, 0~20mA	•Options:0~10V, 0~20mA
		•参考电位为GND	•The reference potential is GND
PTC/KTY 接口	PTC/KTY interface	1通道电机温度检测接口	1 motor temperature detection interface
		•可接的传感器类型PTC、 KTY84	•Available sensor types: PTC, KTY84
		•温度精度±5°C	•Humidity accuracy ±5°C
		集成的总线接口	Integrated bus interface
Modbus RTU	Modbus RTU	RS485通讯接口,带隔离和终端电 阻开关,最大波特率:115.2kbps	RS485 interface, with isolator and bus terminator, 115.2kbps maximum baud rate
CANopen	CANopen	CAN通讯接口,带隔离和终端电阻 开关,最大波特率:1Mbps	CAN interface, with isolator and bus terminator, 1Mbps maximum baud rate

选件接口	Optional interface			
操作面板	Operator Panel		LCD中英文显示操作面板, 支持直接安装和柜门安装	Chinese and English LCD display operation panel, support for direct installation and cabinet door installation.
PC接口	PC interface		USB接口 (通过USB电缆可以和PC机连接)	USB interface(Connecting to PC via USB cable) (developing)
开环-闭环控制功能	Open loop and closed loop control functions			
线性/抛物线/可编程的V/f控制	Linear/parabolic/programmable V/F control	√		
无传感器的速度矢量控制	Speed vector control with no sensors	√		
有传感器的速度矢量控制	Speed vector control with sensors	√		
应用宏	The macro application	√		
设定值输入可参数标定	Parameter calibration for input of set value	√		
固定频率	The fixed frequency		16, 可编程	16, programmable
JOG	JOG	√		
电动电位计	Electric potentiometer	√		
斜坡平滑	Slope smoothing	√		
斜坡函数发生器	Ramp function generator	√		
滑差补偿	Slip compensation	√		
互联参数技术	Interconnection parameter technology	√		
示波器功能 (TRACE)	Oscilloscope function (TRACE)	√		
可切换的驱动参数组	Switchable set of driver parameters		4组	4
可切换的命令参数组	Switchable set of command parameters		4组	4
自由功能块功能, 逻辑与运算	Free functional block function	√		
内置过程PID	The process controller with built-in PID	√		
转速跟踪	Speed tracking	√		
电源瞬停自动再起	The power supply stops immediately and restarts automatically	√		
电机温度保护	Motor temperature protection	√		
变频器温度保护	Driver temperature protection	√		
电机参数识别	Motor identification	√		
电机抱闸控制	Motor lock control	√		
自动最大电压控制 (Vdcmax 控制)	Automatic maximum voltage control (Vdcmax control)	√		
动态缓冲功能 (Vdcmin 控制)	Kinetic buffering function (Vdcmin control)	√		
制动功能	Braking functions		直流制动, 复合制动, 外置制动电阻制动	DC braking, compound braking, external braking resistor
机械和环境要求	Mechanical and environmental requirements			
防护等级	Degree of protection	IP20		
端子接线截面积	Signal cable cross-section	0.05 mm <sup>2</sup> (AWG30)		
		1.5 mm <sup>2</sup> (AWG16)		
运行温度	Operating temperature	-20°C~+50°C		
存储温度	Storage temperature	-40°C~+70°C		
相对湿度	Relative humidity	<95% RH, 无凝露		<95% RH, no condensation
外形尺寸	Dimensions	宽 (W) mm	Width(W)mm	80
		高 (H) mm	Height(H)mm	268
		深 (D) mm	Depth(D)mm	71
重量 近似值	Weight, approx	0.7 kg		

## 3.6 外形尺寸

## 3.6 Dimensions

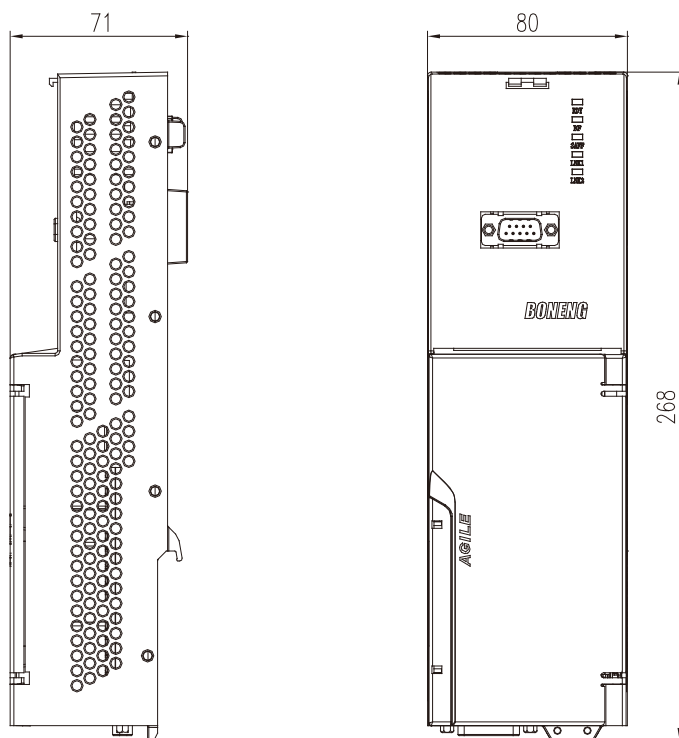

CM25控制模块外形尺寸图, 单位为mm

CM25 Control Module's dimensions (Unit:mm)

## 4 CM22控制模块

### 4.1 概述



CM22控制模块举例

CM22控制模块为驱动器提供闭环控制功能, 作为通用功能设计, 既可以提供V/f控制, 也可以实现矢量控制(有感矢量控制FVC和无感矢量控制SVC), 支持MODBUS通讯协议、增量式光电编码器。

## 4 CM22 Control Module

### 4.1 Summary

CM22 Control Module

CM22 Control Module provides closed-loop control functions for the driver. It can be used to implement all common applications involving V/F or sector control (Inductive vector control FVC and no-inductive vector control SVC), support for MODBUS communication protocol, Incremental photoelectric encoder.

### 4.2 选型订货数据

#### 型号表示方法

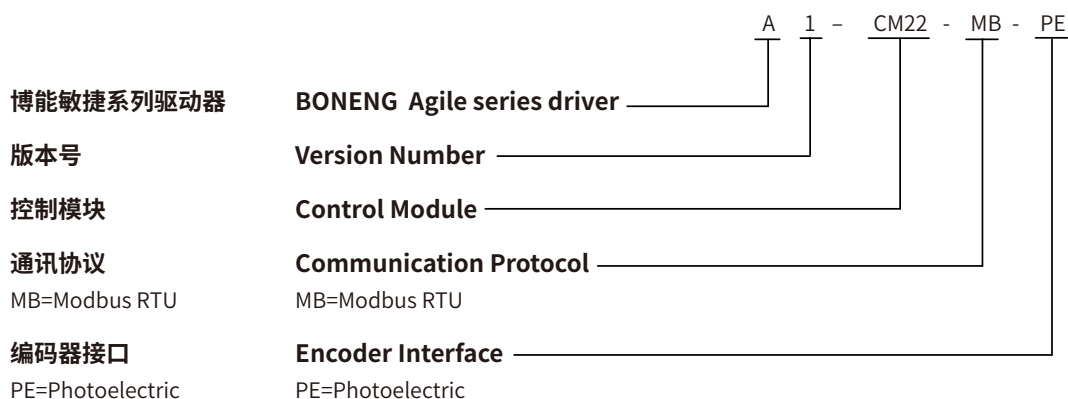

### 4.2 Selective ordering data

#### Model indication method

#### 订货数据

CM22控制模块订货型号为  
A1-CM22-MB-PE

#### Ordering data

The ordering data of Control  
Module CM25 is A1-CM22-MB-PE

### 4.3 设计

### 4.3 Design



CM22控制模块端子盖打开和闭合图

CM22 Control Module's terminal cover (open and closed)

功能	Functions			技术数据	Technical data
通讯功能	Communication function	A1-CM22-MB-PE	A1-CM22-MB-PE	•支持Modbus RTU	• Support for Modbus RTU
外部电源供应	External power supply	通过端子+24V IN和GND IN提供18~30 Vdc, 最大工作电流1A。	Supply 18~30Vdc through terminal+24V IN and GND IN, the maximum operating current is 1A		
输出电源	Output power supply	数字输入端子电源	Digital input terminal power supply	18Vdc~30Vdc, 最大200mA	18Vdc~30Vdc, the maximum is 200mA
		模拟输入端子电源	Analog input terminal power supply	10Vdc~12Vdc, 最大40mA	10Vdc~12Vdc, the maximum is 40mA
		编码器电源	Encoder power supply	24Vdc, 最大350mA	24Vdc, the maximum is 350mA
数字量输入	Digital inputs	5个普通共COM输入	5 common COM inputs	• DI0~DI4 • 电气隔离 • 支持双向输入	• DI0~DI4 • Electrical isolation • Support for two-way input
模拟量输入	Analog inputs	2个通道 (AI0和AI1)	2 channels(AI0 and AI1)	• 差分输入 • 可选择0~10V, -10~+10V和0~20mA • 0~20mA时输入阻抗为500ohm	• Differential input • Options:0~10V, -10~+10V and 0~20mA • The input impedance is 500 ohm at 0~20mA
数字量输出	Digital output	1个继电器输出	1 relay output	• DO1 • 最大30Vdc和0.5A	• DO1 • The maximum is 30Vdc and 0.5A
模拟量输出	Analog output	1个通道 (AO0)	1 channel(AO0)	• 输出0~10V • 参考电位为DGND	• The output is 0~10V • The reference potential is GND
编码器	Encoder	HTL, TTL	HTL, TTL	• 最大频率200kHz • 支持推挽和开集电极编码器 • 支持DC 24V电源 • 电源最大输出350mA	• The maximum frequency is 200kHz • Support for push-pull and open collector encoder. • Operating voltage DC 24V • The maximum power output is 350mA
指示灯	Indicator lights	2个双色指示	2 dichromatic indications	• RDY指示灯, 红绿双色 • BF指示灯, 红绿双色	• RDY indicator light, red and green • BF indicator light, red and green
电磁兼容性	Electromagnetic compatibility	1个单色指示符合标准IEC 61800-3	1 monochromatic indication Comply with the standard IEC 61800-3	• SAFE指示灯, 黄色	• SAFE indicator light, yellow
工作温度	Operating temperature	-20°C~+50°C	-20°C~+50°C		
储存温度	Storage temperature	-40°C~+70°C	-40°C~+70°C		
空气湿度	Air humidity	<95%, 不允许有凝露	<95%, no condensation		

4.4 电气连接

4.4 Electrical connection

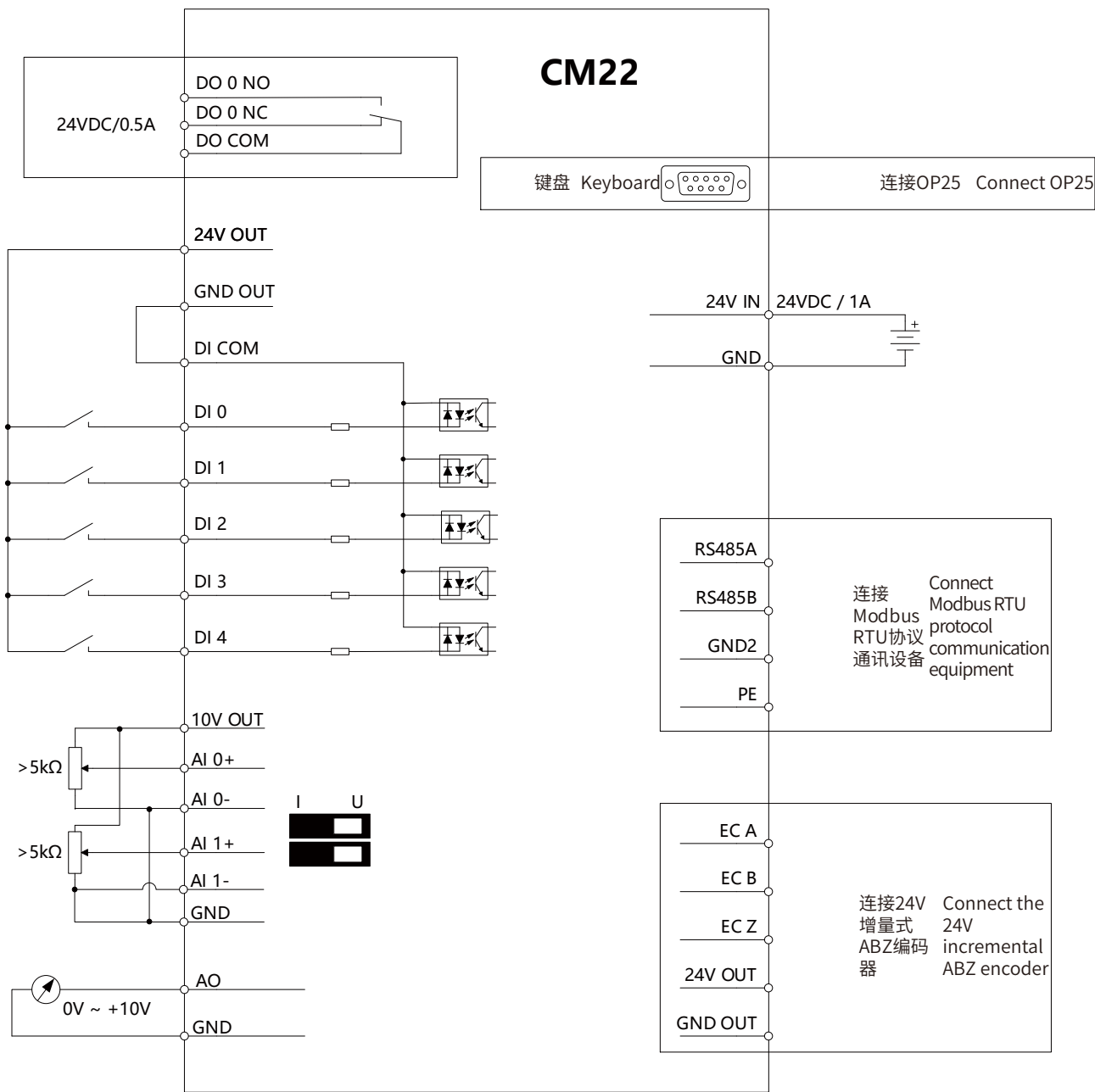

### 4.5 技术参数

### 4.5 Technical parameters

电气参数	Electrical parameters		
工作电压	Operating voltage	通过功率模块的24VDC 或外接20~30VDC电源	
最大电流消耗	The maximum current consumption	≤1.0A	≤1.0A
保护隔离	Protection isolation	PELV 按照 EN50178 标准	PELV in accordance with the standard EN50178
功率损失	Power loss	保护与进线电源分开, 采用双重增强的隔离	
接口	Interfaces	≤10W	≤10W
普通的数字量输入	Common digital inputs	5个共COM输入	
		•DI0~DI4	
		•电气隔离	
模拟量输入	Analog inputs	•支持双向输入	
		2通道输入 (AI0, AI1)	
		•差分输入	
		•可选择0~10V, -10~10V或者0~20mA	
数字量输出	Digital output	•0~20mA时输入阻抗为500Ω	
		1通道继电器输出	
		•D00	
模拟量输出	Analog output	•最大30VDC输出和0.5A	
		1通道输出 (A00)	
		•0~10V	
集成的总线接口	Integrated bus interface	•参考电位为GND	
Modbus RTU	Modbus RTU	RS485通讯接口, 带隔离和总线终端电阻开关, Max Baud: 115.2kbps	RS485 communication interface, with isolation and bus terminal resistance switch. Max Baud:115.2k bps
操作面板	Operator Panel	LCD中英文显示操作面板, 支持直接安装和柜门安装	
开环-闭环控制功能	Open loop and closed loop control function	Chinese and English LCD display operation panel, support for direct installation and cabinet door installation.	
线性/抛物线/可编程的V/F控制	Linear/parabolic/programmable V/F control	√	√
无传感器的速度矢量控制	Speed vector control with no sensors	√	√
有传感器的速度矢量控制	Speed vector control with sensors	√	√
应用宏	The macro application	√	√
设定值输入可参数标定	Parameter calibration for input of set value	√	√
固定频率	The fixed frequency	16, 可编程	16, programmable
JOG	JOG	√	√
电动电位器 (MOP)	Electric potentiometer(MOP)	√	√
斜坡平滑	Slope smoothing	√	√
斜坡函数发生器	Ramp function generator	√	√
滑差补偿	Slip compensation	√	√
互联参数BICO技术	Interconnection parameter BICO technology	√	√
示波器功能 (TRACE)	Oscilloscope function(TRACE)	√	√
可切换的驱动参数组	Switchable set of driver parameters	4组	4
自由功能块功能, 逻辑与运算	Free function block function, logic and operation	√	√
过程控制器内置PID	The process controller with built-in PID	√	√
转速跟踪	Speed tracking	√	√
电源瞬停自动再起	The power supply stops immediately and restarts automatically	√	√
驱动器温度保护	Driver temperature protection	√	√
电机参数识别	Motor identification	√	√
电机抱闸控制	Motor lock control	√	√
自动最大电压控制 (Vdcmx 控制)	Automatic maximum voltage control(Vdcmx control)	√	√
动态缓冲功能 (Vdcmi 控制)	Kinetic buffering function(Vdcmi control)	√	√
制动功能	Braking functions	直流制动, 复合制动, 外置制动电阻制动	DC braking, compound braking, external braking resistor
机械和环境要求	Mechanical and environment requirements		
防护等级	Degree of protection	IP20	IP20
端子接线截面积	Signal cable cross-section	•最小	0.05 mm <sup>2</sup> (AWG30)
		•最大	1.5 mm <sup>2</sup> (AWG16)
运行温度	Operating temperature	-20°C~+50°C	
存储温度	Storage temperature	-40°C~+70°C	
相对湿度	Relative humidity	<95% RH, 无凝露	
外形尺寸	Dimensions	宽 (W) mm	80
		高 (H) mm	208
		深 (D) mm	61
重量 近似值	Weight, approx	0.6kg	0.6kg



## 4.6 外形尺寸

## 4.6 Dimensions

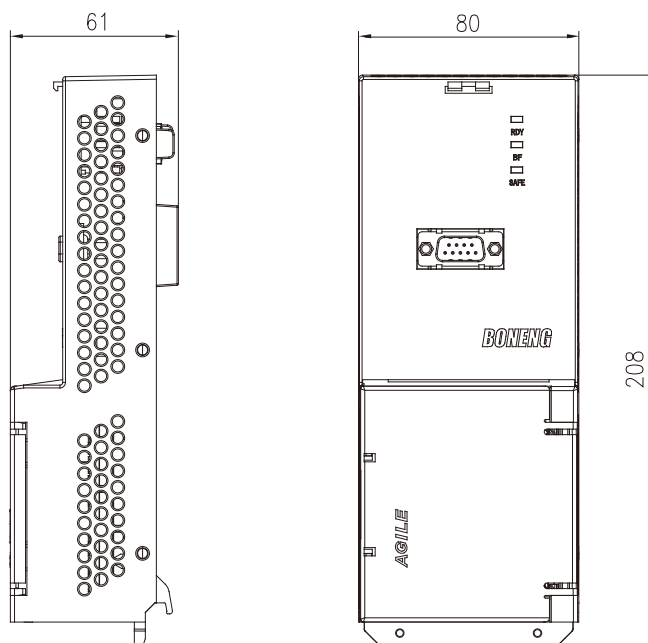

CM22控制模块外形尺寸图, 单位为mm

CM22 Control Module's dimensions (Unit:mm)

## 5 CM23控制模块

### 5.1 概述



CM23控制模块

CM23驱动模块为驱动器提供闭环控制功能, 作为通用功能设计, 既可以提供V/f控制, 也可以实现矢量控制 (有感矢量控制FVC和无感矢量控制SVC), 支持Modbus RTU通讯协议、PROFINET通讯协议、增量式编码器。

## 5 CM23 Control Module

### 5.1 Summary

CM23 Control Module provides closed-loop control functions for the driver. It can be used to implement all common applications involving V/f or sector control (Inductive vector control FVC and no-inductive vector control SVC), support for Modbus RTU and PROFINET communication protocol, Incremental photoelectric encoder.

### 5.2 选型订货数据 型号表示方法

### 5.2 Selective ordering data Model indication method

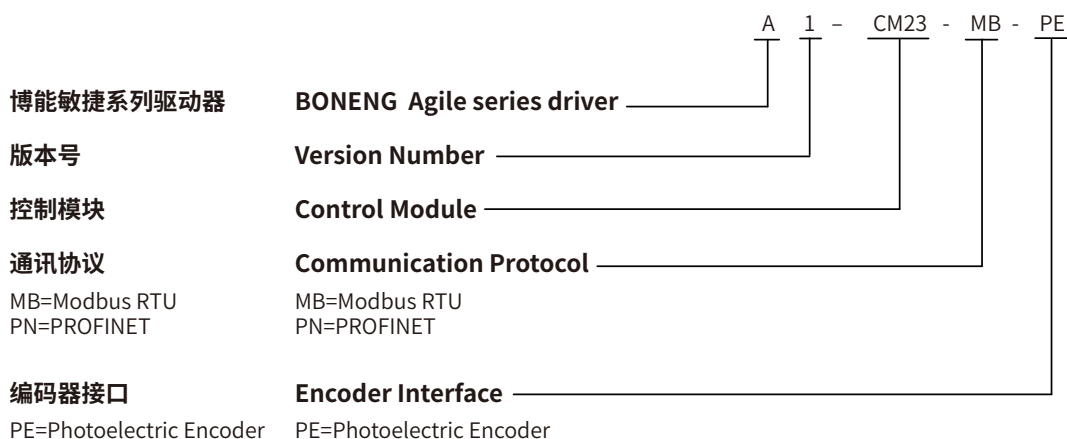

接口类型	Interface types	订货号	Ordering data
支持Modbus RTU通讯协议; 增量式编码器	Modbus RTU communication protocol; Incremental encoder	A1-CM23-MB-PE	
支持PROFINET 通讯协议; 增量式编码器	PROFINET communication protocol; Incremental encoder	A1-CM23-PN-PE	

### 5.3 设计

### 5.3 Design



CM23控制模块端子盖打开和闭合图

CM23 Control Module's terminal cover (open and closed)

功能	Function	技术数据	Technical data		
总线接口	Bus interface	A1-CM23-MB-PE	A1-CM23-MB-PE	•支持Modbus RTU 通讯	•Support Modbus RTU communication
		A1-CM23-PN-PE	A1-CM23-PN-PE	•波特率: 最大 115200bps	•Baud rate: 115200bps at most
工作电源	Working power supply	功率模块供电	Power supply of power module	•支持PROFINET	•Support PROFINET communication
		+24V输出	+24 V output	•RJ45接口	•BRJ45 interface
输出电源	Output power supply	编码器电源	Encoder power supply	•24V/0.6A	•24V/0.6A
		+24V输出	+24 V output	•电压范围: DC 18V ... 26.8V	•Voltage range: DC 18V...26.8V
数字量输入	Digital inputs	6个 (DI0 ~ DI5)	6 (DI0 ~ DI5)	•最大电流: 200mA	•Maximum current: 200mA
		2个继电器 (DO0~DO1)	2 relays (D00 ~ D01)	•电压范围: DC 18V ... 26.8V	•Voltage range: DC 18V...26.8V
数字量输出	Digital outputs	2个继电器 (DO0~DO1)	2 relays (D00 ~ D01)	•最大电流: 200mA	•Maximum current: 200mA
		增量式ABZ编码器	Incremental ABZ encoder	•公共端子DICO M0	•Common terminal DICO M0
指示灯	Indicator lights	2个双色指示灯	2 dichromatic indications	•电气隔离	•Electrical isolation
		1个单色指示灯	1 monochromatic indication	•支持Source和Sink 模式	•Support source and sink mode
键盘接口	Keyboard interface	支持OP25	Support OP25	•电压: DC 24V、AC 36V、AC48V	•Voltage: DC 24 V, AC 36 V, AC 48 V
		支持OP25	Support OP25	•"1"信号电压: >11V	•"1" signal voltage: > 11 V
工作温度	Working temperature	-20°C~+50°C	-20°C~+50°C	•"0"信号电压: <5V	•"0" signal voltage: < 5V
		-20°C~+50°C	-20°C~+50°C	•24V典型电流: 4mA	•24 V typical current: 4 mA
存储温度	Storage temperature	-40°C~+70°C	-40°C~+70°C	•响应时间: 6ms (含软件滤波)	•Response time: 6ms (including software filtering)
		-40°C~+70°C	-40°C~+70°C	•电压: DC 24V、AC 220V	•Voltage: DC 24 V, AC 220 V
相对空气湿度	Relative air humidity	<95%	<95%	•连续电流: 2A	•Continuous current: 2A
		<95%	<95%	•切换电流: 2A	•Switching current: 2A
污染	Pollution	符合IEC 61800-5-1	Comply with IEC 61800-5-1	•触点类型: 1常开 1常闭	•Contact type: 1 normally open and 1 normally closed
		符合IEC 61800-3	Comply with IEC 61800-3	•支持24V的单端信号	•Support single ended signal of 24 V
电磁兼容性	Electromagnetic compatibility	符合IEC 61800-3	Comply with IEC 61800-3	•输入频率: 最大 200kHz	•input frequency: maximum 200kHz
		符合IEC 61800-3	Comply with IEC 61800-3	•电缆长度: 24V开集电极类型50m;24V推挽类型100m	•Cable length: 24 V open collector type 50 m;24 V push pull type 100 m
				•RDY指示灯: 红绿双色	•RDY indicator: red and green
				•BF指示灯: 红绿双色	•BF indicator: red and green
				•SAFE指示灯: 黄色	•SAFE indicator: yellow
				•可直接安装或外引安装	•Direct installation or external installation
				不允许有凝露	No condensation
				适用于污染等级 2 的环境	Suitable for pollution level 2 environment

5.4 电气连接

5.4 Electrical connection

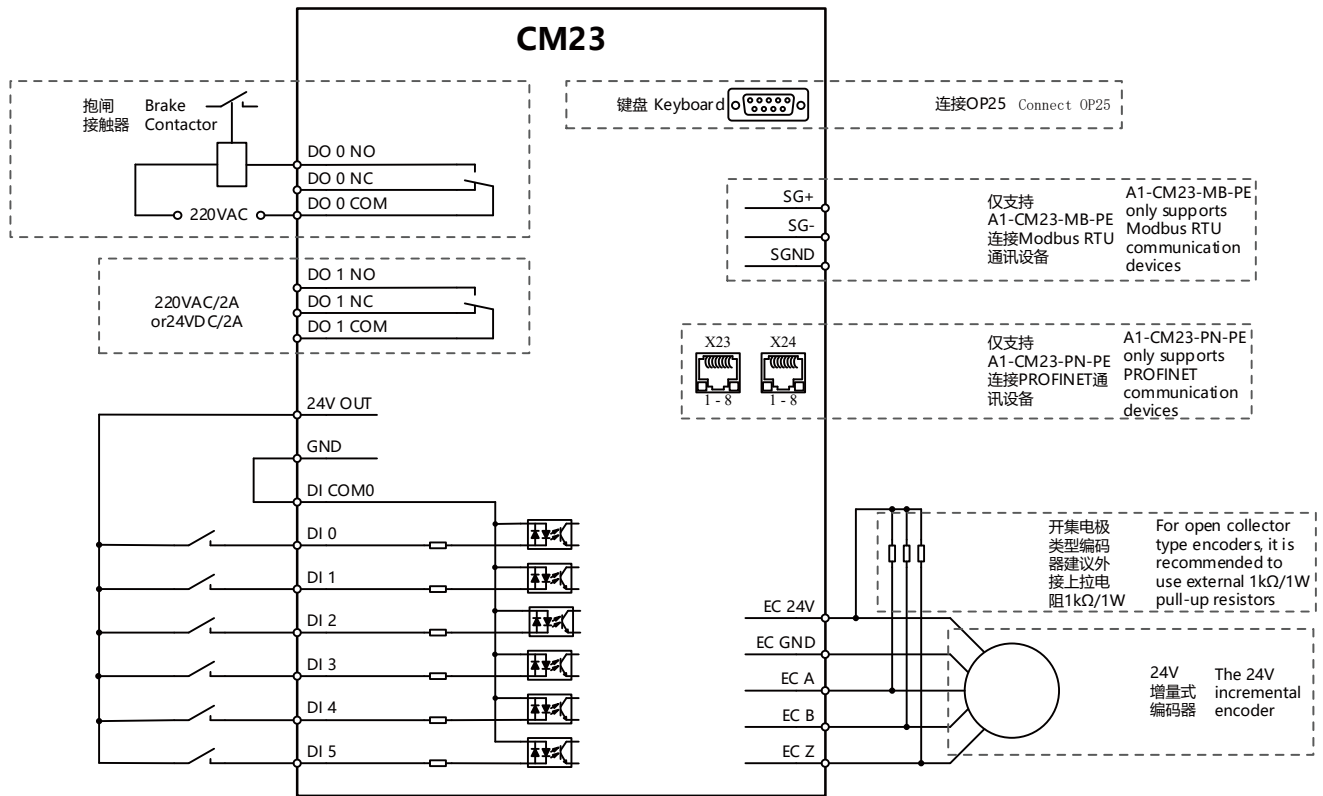

## 5.5 技术参数

## 5.5 Technical parameters

电气参数		Electrical parameters		
工作电压	Operating voltage	通过功率模块的24VDC 24VDC through power module		
最大电流消耗	Maximum current consumption	≤1A ≤1A		
保护隔离	Protective isolation	PELV按照EN50178标准	PELV in accordance with the standard EN50178	
		保护与进线电源分开, 采用双重隔离	Protection separated from incoming power, adopts dual-enhanced isolation.	
接口		Interfaces		
普通数字量输入	Common digital inputs	6个共COM输入 6 common COM inputs	DI 0 ~ DI 5	DI 0 ~ DI 5
			电气隔离	Electrical isolation
			支持双向输入	Support two-way input
模拟量输入	Analog input	不支持 Not supported		
数字量输出	Digital outputs	2个继电器输出 2 relay outputs	DO0, DO 1	DO0, DO 1
			支持250VAC、30VDC	Support 250VAC、30VDC
			最大电流2A	Maximum current 2A
模拟量输出	Analog output	不支持 Not supported		
集成的总线接口		Integrated bus interface		
Modbus RTU	Modbus RTU	RS485通讯接口,带隔离,最大波特率:115.2kbps	RS485 communication interface, with isolation, maximum baud rate: 115.2kbps	
Profinet	Profinet	RJ45	RJ45	
选件接口		Optional interfaces		
操作面板	Operation Panel	可选OP25,支持直接安装和外引安装	OP25 can be selected to support direct installation and external installation	
开环-闭环控制功能		Open loop and closed loop control function		
线性/抛物线/可编程的V/F控制	Linear/parabolic/programmable V/F control	√	√	
无传感器的速度矢量控制	Speed vector control with no sensors	√	√	
有传感器的速度矢量控制	Speed vector control with sensors	√	√	
应用宏	Macro application	√	√	
设定值输入可参数标定	Parameter calibration for input of set value	√	√	
固定频率	Fixed frequency	16, 可编程	16, programmable	
JOG	JOG	√	√	
电动电位器(MOP)	Electric potentiometer(MOP)	√	√	
斜坡平滑	Slope smoothing	√	√	
斜坡函数发生器	Ramp function generator	√	√	
滑差补偿	Slip compensation	√	√	
互联参数BICO技术	Interconnection parameter BICO technology	√	√	
示波器功能(TRACE)	Oscilloscope function(TRACE)	√	√	
可切换的驱动参数组	Switchable set of driver parameters	4组	4	
自由功能块功能,逻辑与运算	Free function block function, logic and operation	√	√	
转速跟踪	Speed tracking	√	√	
电源瞬停自动再起	The power supply stops immediately and restarts automatically	√	√	
驱动器温度保护	Driver temperature protection	√	√	
电机参数识别	Motor identification	√	√	

## 5.6 外形尺寸

## 5.6 Dimensions

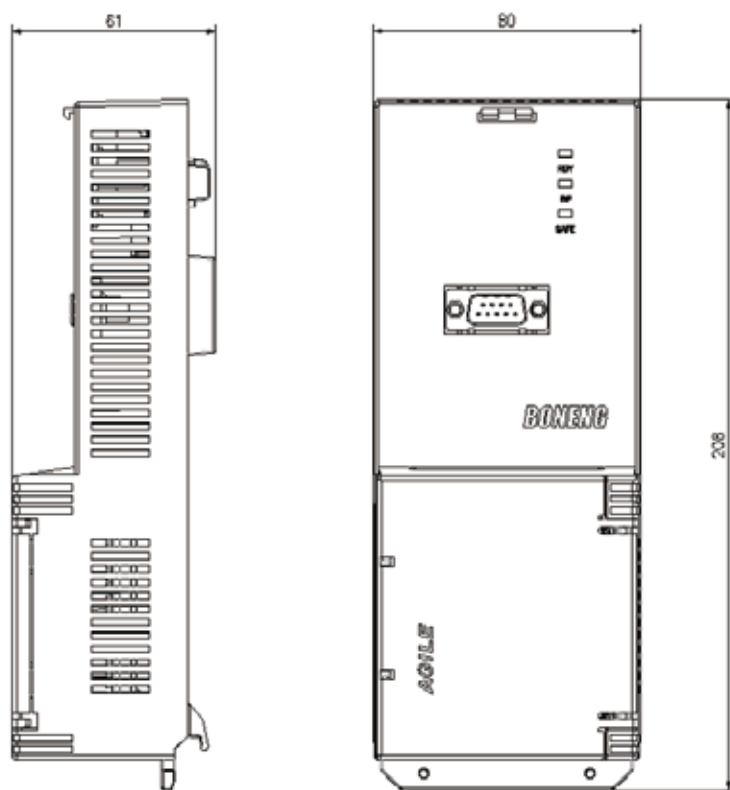

CM23外形尺寸图, 单位为mm

CM23 Control Module's dimensions (Unit:mm)

## 6 OP25操作面板

### 6.1 概述

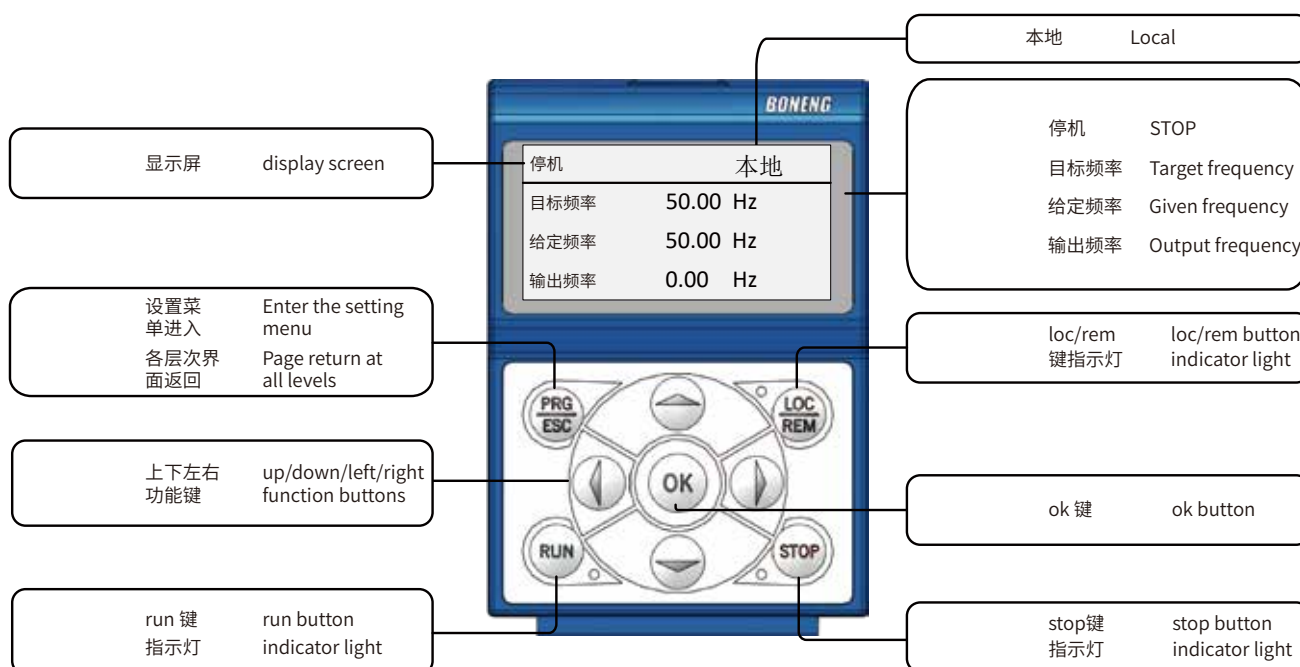

OP25操作面板举例

通过菜单导航和128\*64点阵LED显示屏,可以显示3行参数和1行状态显示,使得驱动器的调试变得非常简单,操作面板不仅可以同时显示参数名称和参数值,还具有参数过滤功能,这使得基本的驱动器调试变得简单容易,而且绝大多数的操作都无需纸质版说明书或参数手册。

通过操作面板的上、下、左、右、启动(RUN)、停止(STOP)、确认(OK)和返回(PRG/ESC)八个按键,可以方便地对驱动器参数进行本地设置。同时,操作面板上有一个专门的按键可以完成面板/远程的直接切换。

驱动器的故障诊断可以通过菜单的引导来完成,当前最新故障也会显示在主界面上直到故障消失或人为清除,提高了操作的便利性和安全性。

驱动器的当前参数可以拷贝到操作面板,并在必要的时候下载到相同类型的驱动器中。操作面板的背光延时时间和屏幕显示对比度可设置。

OP25操作面板的工作温度为-10°C~+50°C

## 6 OP25 Operation Panel

### 6.1 Summary

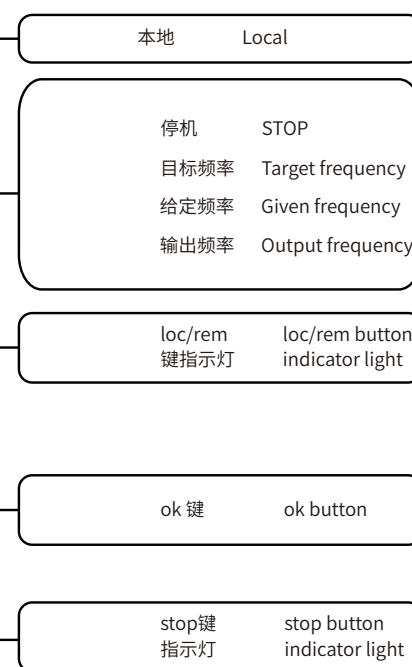

OP25 Operation Panel

Through the menu navigation and 128\*64 dot LED display screen, 3 rows of parameters and 1 row status can be displayed, making the debugging of the driver very simple. The operation panel can not only display the parameter name and parameter value at the same time, but also has the parameter filtering function, and most operations do not need paper manual or parameter manual. The driver's parameters can be set locally through these 8 buttons: top, bottom, left, right, RUN, STOP, OK and PRG/ESC. At the same time, there is a specific button on the panel to complete the panel/remote direct switch.

The driver's faulty diagnosis can be accomplished through menu's guide, and the current latest fault will be displayed on the main page until eliminating the fault or clearing manually, which improves the convenience and security of the operation. The current parameters of driver can be copied to the operation panel and downloaded to the same type of drive if necessary.

The backlight delay time and screen display contrast of the operation panel can be set. The working temperature of OP25 is 0°C ~+50°C.

### 6.2 选型订货数据

### 6.2 Selective ordering data

#### 型号表示方法

#### Model representation

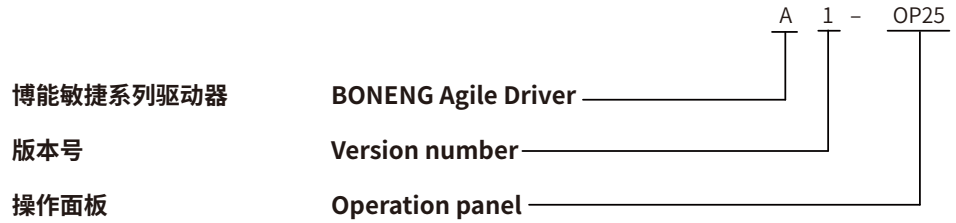

#### 订货数据

#### Ordering data

OP25操作面板订货型号为A1-OP25

Ordering data of operation panel OP25 A1-OP25

### 6.3 外形尺寸

### 6.3 Dimensions

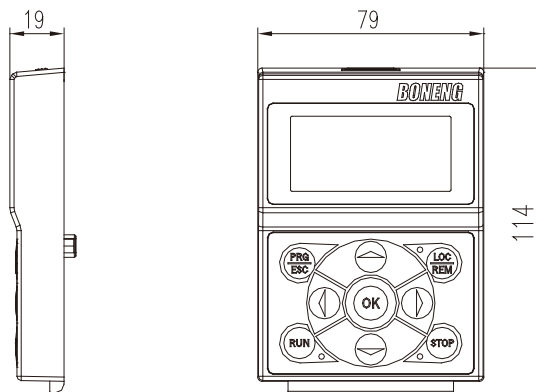

OP25操作面板外形尺寸图, 单位为mm

OP25 Operation Panel's dimensions (Unit:mm)

随着技术迭代进步, 博能产品样本将会同步更新, 请见谅。  
 Along with the technology advancedet.,the product of the manual of Boneng will be changed,please forgive.



# 博能产品集成图

# Boneng Product Integration Diagram

CONTROL  
控制层

DRIVE  
驱动层

MOTOR  
马达层

GEAR  
齿轮层

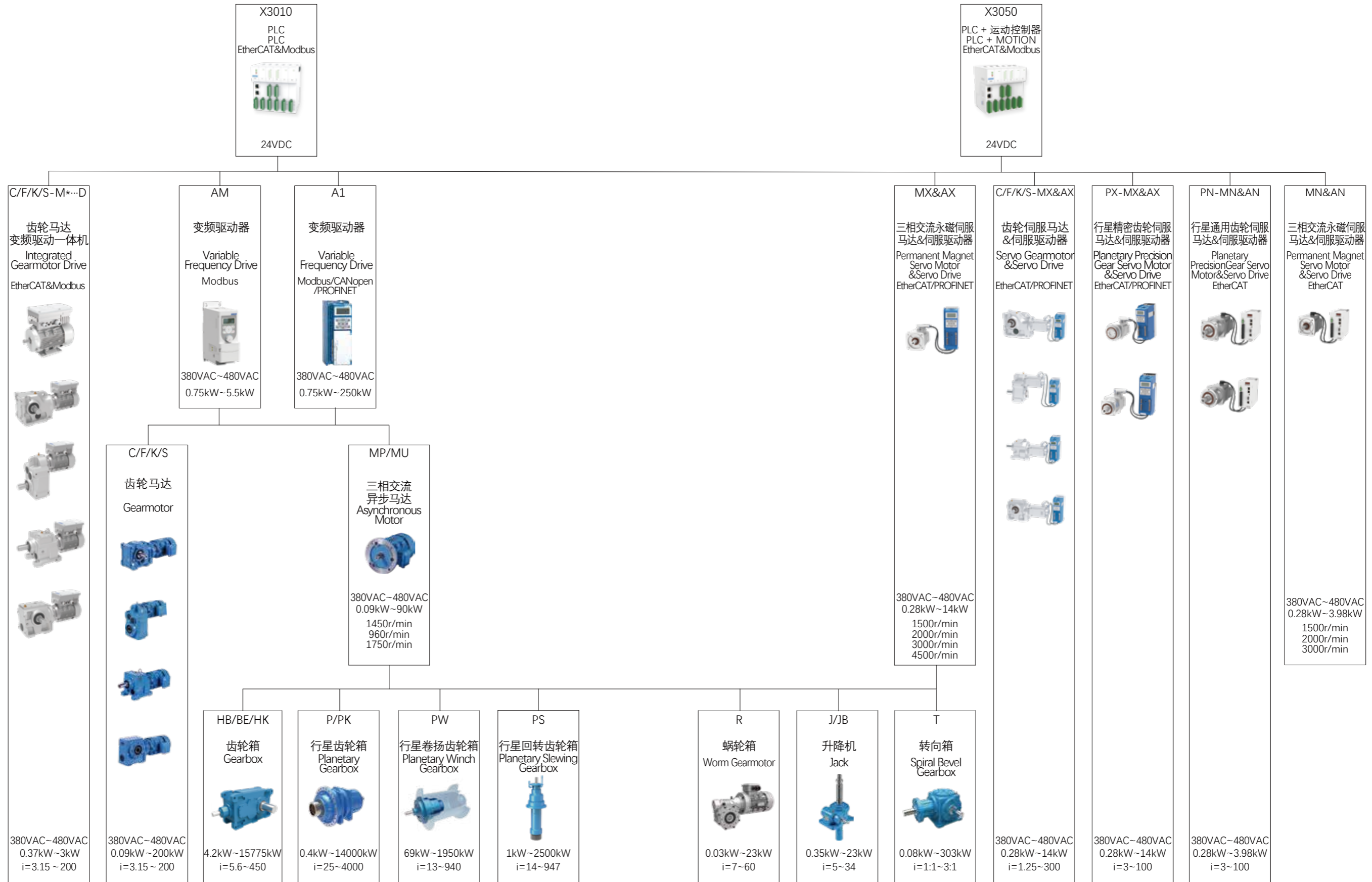

<b>博能传动(沈阳)有限公司</b>	<b>BONENG TRANSMISSION(SHENYANG)CO.,LTD.</b>
辽宁省沈阳市沈北新区 太平洋工业城A区A73-6号 电话: 024-31271571	No. A73-6, Area A, Pacific Industrial City, Shenbei New District, Shenyang, Liaoning Province, China TEL: 024-31271571
<b>博能传动(天津)有限公司</b>	<b>BONENG TRANSMISSION(TIANJIN)CO.,LTD.</b>
天津市北辰区双海道6号 宏鹏工业园7号车间 电话: 022-26929556	7th Workshop, Hongpeng Industrial Park, No. 6 Shuanghai Road, Beichen District, Tianjin City,China TEL: 022-26929556
<b>博能传动(潍坊)有限公司</b>	<b>BONENG TRANSMISSION(WEIFANG)CO.,LTD.</b>
山东省潍坊市安丘市经济开发区 汶水路与昆仑大街交叉口往北 100米路东1号车间 电话: 0536-2141166	1st Workshop, Economic Development Zone, Anqiu, Weifang City, Shandong Province, China TEL: 0536-2141166
<b>博能传动(开封)有限公司</b>	<b>BONENG TRANSMISSION(KAIFENG)CO.,LTD.</b>
河南省开封市宋城路四大街11号 海神机械院内五号厂房 电话: 0371-23335238	5th Workshop, Haishen Machinery, No.11, Fourth Street, Songcheng Road,New District, Kaifeng City, Henan Province, China TEL: 0371-23335238
<b>博能传动(长沙)有限公司</b>	<b>BONENG TRANSMISSION(CHANGSHA)CO.,LTD.</b>
湖南省长沙市望城经济开发区 普瑞大道1288号 电话: 0731-88386958	No. 1288 Puri Avenue, Wangcheng Economic Development Zone, Changsha City, Hunan Province, China TEL: 0731-88386958
<b>博能传动设备(成都)有限公司</b>	<b>BONENG TRANSMISSION EQUIPMENT(CHENGDU) CO., LTD.</b>
四川省成都市金牛区金牛坝路9号5栋 向荣中心A座7楼-703 电话: 028-87741100	703, 7th Floor, Block A, Xiangrong Center, Building 5, No. 9 Jinniuba Road, Jinniu District, Chengdu City, Sichuan Province, China TEL: 028-87741100
<b>博能传动(肇庆)有限公司</b>	<b>BONENG TRANSMISSION(ZHAOQING)CO.,LTD.</b>
广东省肇庆市鼎湖区肇庆新区 科创大道7号平谦国际现代产业园 一期A12北厂房 电话: 0757-86719757	No. 7 Science and Technology Innovation Avenue, Zhaoqing New Area, Dinghu District, Zhaoqing City, Guangdong Province, China TEL: 0757-86719757
<b>博能传动(苏州)有限公司</b>	<b>BONENG TRANSMISSION(SUZHOU)CO.,LTD.</b>
江苏省苏州市相城区如元路100号 电话: 0512-66189662	No. 100, Ruyuan Road, Xiangcheng District, Suzhou, Jiangsu Province, China TEL: 0512-66189662

<b>博能传动(美国)有限公司</b>	<b>BONENG TRANSMISSION(USA)LLC.</b>
1250 E 222nd Euclid, OH 44117, United Staes TEL: 1-216-618-0138 TEL: 1-216-618-0496 TEL: 1-216-618-3099	1250 E 222nd Euclid, OH 44117, United Staes TEL: 1-216-618-0138 TEL: 1-216-618-0496 TEL: 1-216-618-3099
<b>博能传动(印度)有限公司</b>	<b>BONENG TRANSMISSION(INDIA)PVT.LTD</b>
Plot No. E-10/3, MIDC sinnar (Malegaon) Industrial Area, Nashik, 422123, Maharashtra, India. TEL:+91-11- 4507 6293 (DELHI) TEL:+91-22-2781 3385 (MUMBAI)	Plot No. E-10/3, MIDC sinnar (Malegaon) Industrial Area, Nashik, 422123, Maharashtra, India. TEL:+91-11- 4507 6293 (DELHI) TEL:+91-22-2781 3385 (MUMBAI)

A1 变频驱动器

A1 variable frequency drive

**BONENG**